

Unicla[®]

eDrive[™]

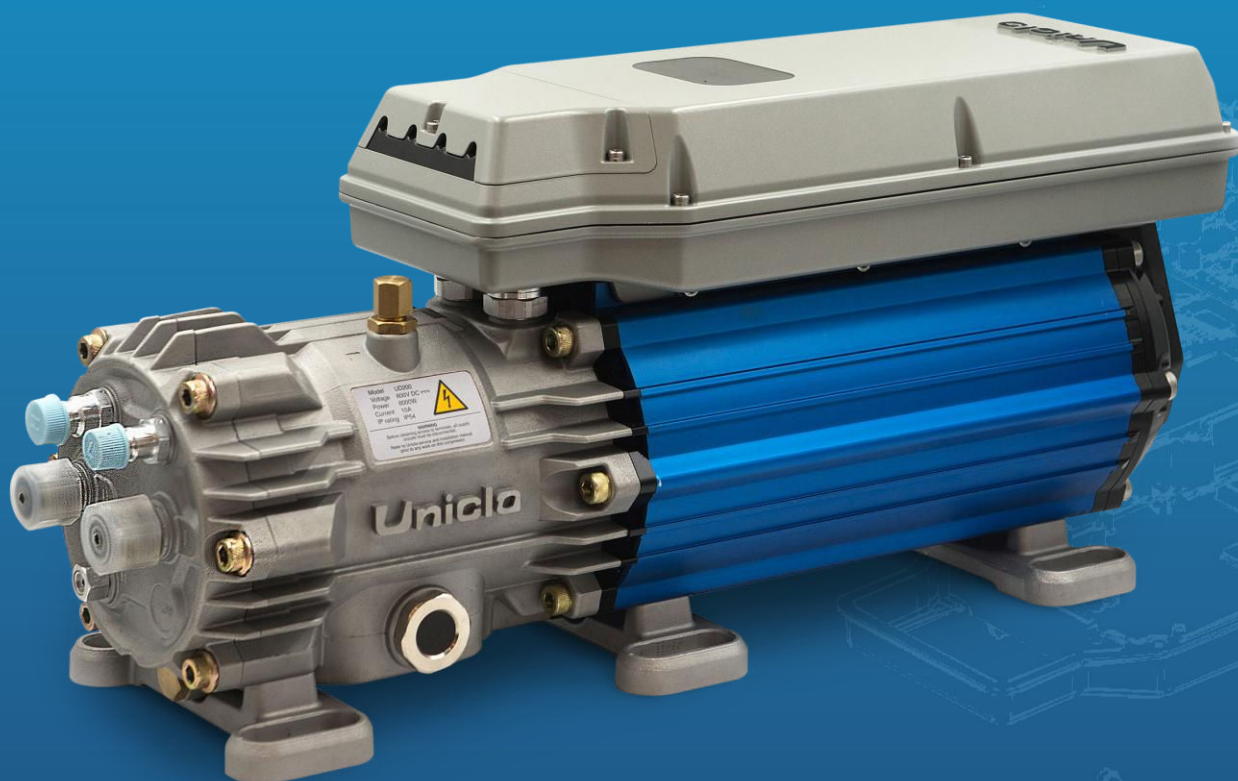

**UD150 | UDF150 / UDH150 |
UD200**

Installation and operation
manual

400 and 600 Vdc series

Unicla®

Copyright © 2020 All rights reserved

No part of this document shall be reproduced in whole or in part without the permission of Unicla International Limited. This includes reproduction or copies in any form or by any means including photocopying, printing or electronic media.

IMPORTANT DISCLAIMER

This is a guideline document containing professional information using representative graphs, charts and tables. Manufacturers' specifications must be consulted for specific guidelines and performance data. Unicla published data, specific to all models, is available in promotional literature and from Unicla International Limited on request or through your Unicla supplier.

Unicla International Limited expressly disclaims all and any liability and responsibility to any person or business as a result of any actions taken on the basis of information in this publication.

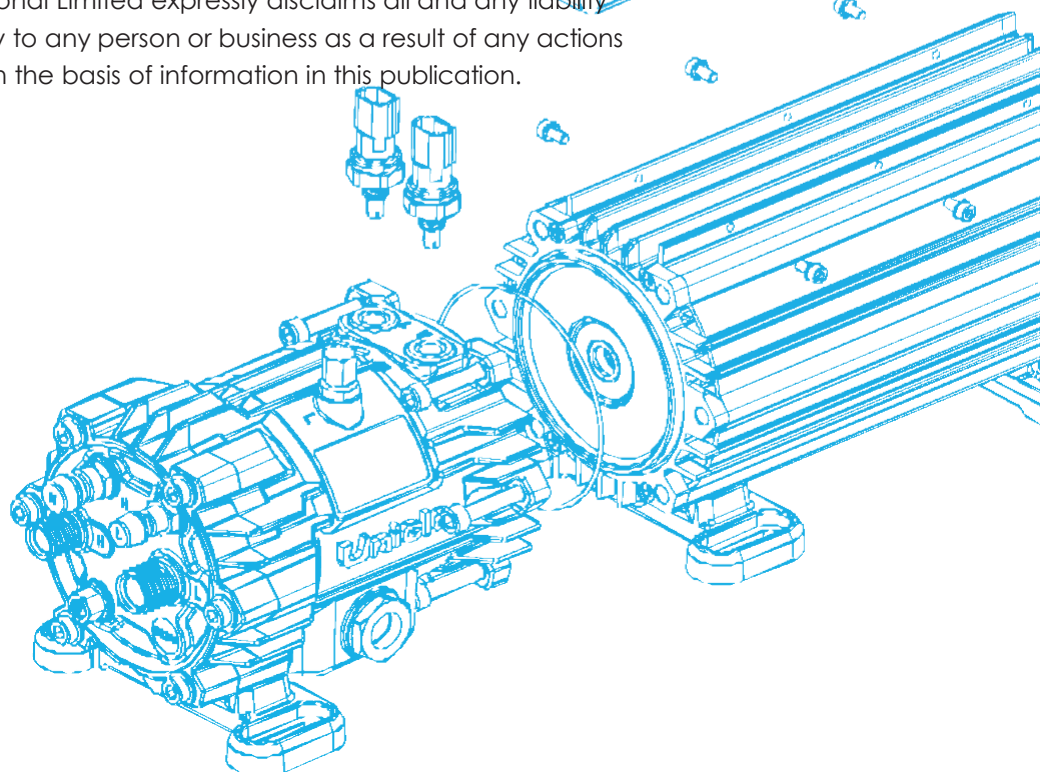
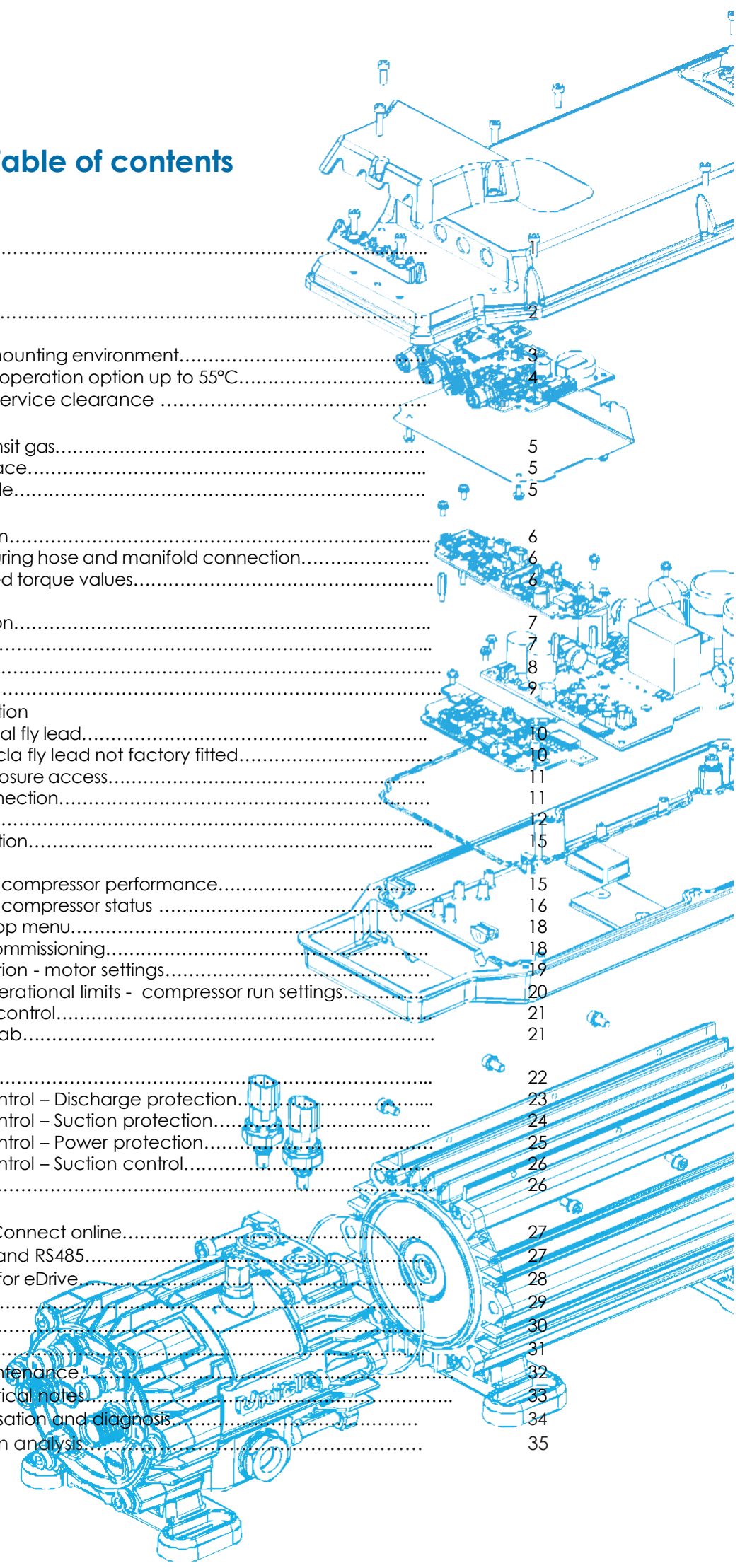

Table of contents

Important safety and handling.....	
1. Introduction.....	2
2. Installation planning	
2.1 Compressor mounting environment.....	3
2.2 High ambient operation option up to 55°C.....	4
2.3 Compressor service clearance	5
3. Installation	
3.1 Removing transit gas.....	5
3.2 Mounting surface.....	5
3.3 Mounting angle.....	5
4. System assembly	
4.1 Contamination.....	6
4.2 Cleanliness during hose and manifold connection.....	6
4.3 Recommended torque values.....	6
5. System oil	
5.1 Oil specification.....	7
5.2 Oil quantity.....	7
6. Oil separator.....	8
7. Refrigerant charging.....	9
8. Compressor electrical connection	
8.1 Uniclac electrical fly lead.....	10
8.2 Variation – Uniclac fly lead not factory fitted.....	10
8.3 Electrical enclosure access.....	11
8.4 Electrical connection.....	11
9. Cable options.....	12
10. Integrated motor load protection.....	15
11. eConnect app	
11.2 Dashboard – compressor performance.....	15
11.3 Dashboard – compressor status	16
11.4 eConnect app menu.....	18
11.5 eConnect commissioning.....	18
11.6 Control function - motor settings.....	19
11.7 User level operational limits - compressor run settings.....	20
11.8 Oil balance control.....	21
11.9 Information tab.....	21
12. Adaptive control	
12.1 Introduction.....	22
12.2 Adaptive control – Discharge protection.....	23
12.3 Adaptive control – Suction protection.....	24
12.4 Adaptive control – Power protection.....	25
12.5 Adaptive control – Suction control.....	26
13. Fault output	26
14. Other communication	
14.1 Online via eConnect online.....	27
14.2 eDrive CAN and RS485.....	27
15. Compressor status messages for eDrive.....	28
16. Starting the system.....	29
17. Troubleshooting guide.....	30
18. General internal layout.....	31
19. Operational checks and maintenance.....	32
20. Installation, control and electrical notes.....	33
21. Compressor sight glass visualisation and diagnosis.....	34
22. eDrive compressor operation analysis.....	35



Important safety and handling

- Refrigerant systems and components contain gases under pressure and may be worked on only by suitably qualified and competent persons.
- Always carry out a risk assessment before starting any work on the system and compressor.
- Always use appropriate protective equipment where required such as safety glasses, gloves and safety boots.
- All electrical work may be carried out only by suitably qualified and competent persons in accordance with national and local safety regulations. All electrical work carries a risk of death or serious injury.
- Under no circumstances should any attempt be made to repair the PCB logic boards. Should a problem develop with these components, contact your nearest Unicla dealer.
- Under no circumstances should the PCB logic boards be electrically probed at any point, other than the connector terminals where the harness attaches to verify supply voltage. Internal components operate at different voltage levels and at extremely low current levels. Improper use of voltmeters, jumper wires, continuity testers and similar equipment could permanently damage the processor.
- Most electronic components are susceptible to damage caused by electrical static discharge (ESD). In certain cases, the human body can generate enough static electricity to damage the components by touch.
- The use of A2 and A3 classification hydrocarbon refrigerants is not permitted due to their flammability. Hydrocarbon refrigerants would include, but is not limited to, Propane (R290), Butane (R600) and Isobutane (R600a). Unicla eDrive compressors are not designed for such refrigerants, and any such use could result in fire or explosion. Refrigerants in the A2L classification such as R1234yf are excluded in this directive because of their lower flammability rating.

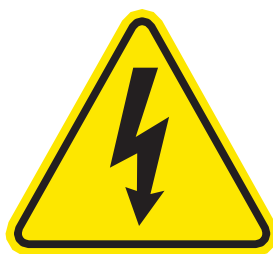

1. Introduction

The Unicla eDrive is a unique compressor design which incorporates the extensively field-tested and proven Unicla swashplate compressor with the energy efficiency of a brushless and sensorless variable speed Vdc motor, managed by the Unicla motor control module.

This booklet and referenced support documents will assist technical personnel to install the eDrive compressor in accordance with correct fitting procedures to maximise the life of the compressor. Unicla compressors are manufactured with quality materials to exacting standards and subjected to rigorous test programs to optimise reliability and durability.

It is important to recognise that poor installation and servicing procedures, as well as any mismatch of the system components can seriously jeopardise compressor reliability and performance. Failure to

follow the installation guidelines and refrigerant best practice can result in unacceptable system performance or premature compressor failure which is not covered by the Unicla compressor warranty. Therefore, the guidelines in this booklet must be strictly adhered to and must be considered in conjunction with Unicla instruction booklets and reference material:

Unicla Booklet B1801 - The importance of suction lines: Analysis and connection to compressors

Unicla Booklet B1802 - Oil and compressor lubrication

Unicla Booklet S2102, S2103, S2104, S2108, S2110 - Product bulletins (according to specific model)

Unicla Booklet T2311, T2312, T2313, T2314 - Motor information (according to specific model)

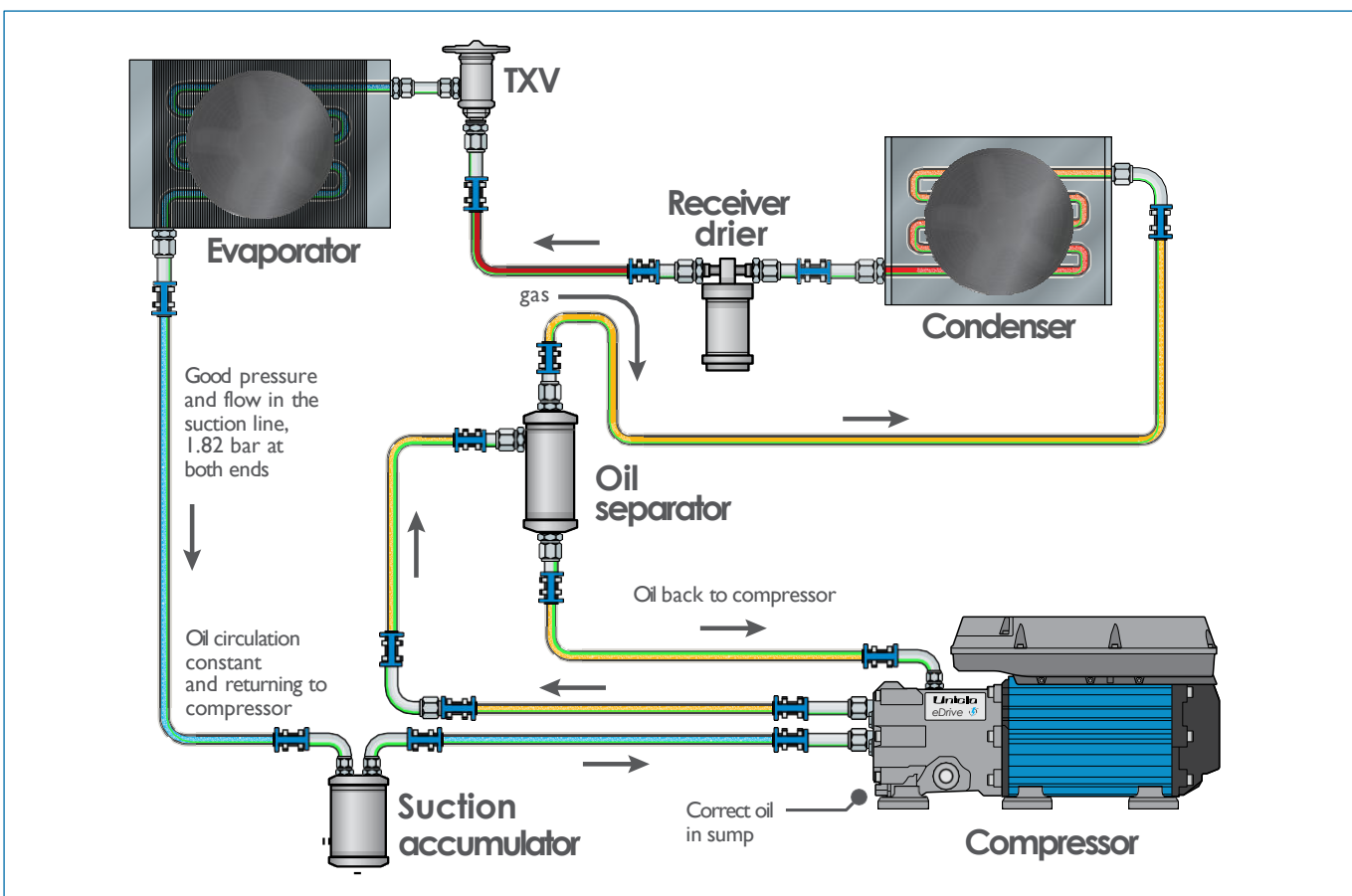

System schematic with optional suction accumulator and oil separator

2. Installation planning

2.1 Compressor mounting environment

The compressor motor and electrical enclosure are air cooled and require clearance at the rear of the compressor to allow unobstructed air flow.

The mounting area should:

- be a ventilated space not closed to air circulation (required for heat removal – see below)
- have an installation cabinet temperature not exceeding 40°C (air temperature onto the motor)
- not be exposed to high pressure water or driving rain
- not be positioned near any heat generating components such as heaters, transformers and brake assemblies
- be free from excessive dust or debris that could block the fan intake
- be a non-corrosive environment.

The image below indicates the movement direction of cooling air through the compressor and the minimum clearances required for installation.

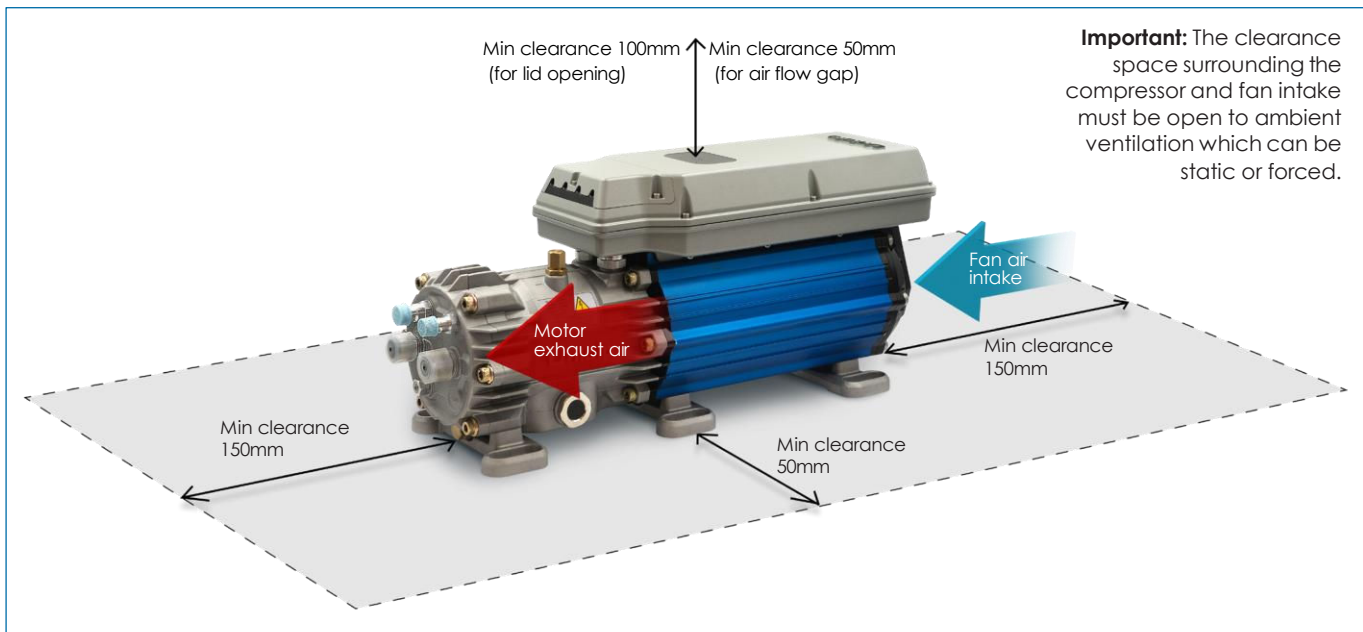

Compressor clearance and air direction in static ambient conditions up to 40°C

2.2 High ambient operation option up to 55°C

This high ambient solution is generally only suited to low pressure refrigerants such as R134a and R1234yf, or typically air conditioning systems. It must be noted that high ambient temperature operation is possible only when the system is operating within the recommended Unicla inside envelope (refer datasheet). Conditions outside this envelope may cause motor, compressor and control systems to reach safety limits that require de-rating of the compressor performance.

To ensure adequate eDrive operation the installation must incorporate additional airflow over the body of the motor and electrical housing. The temperature of this cooling air flow onto the compressor must not exceed the specified ambient limit (up to 55°C).

Airflow requirements:

- Airflow must measure at least four metres per second along the surfaces of the electrical enclosure and motor as shown in the illustration below. Air flow can be only in the direction shown (reverse air flow is not allowed).
- Hot air discharge from the compressor must direct away and out of the compressor space ensuring hot air discharge cannot be recirculated, trapped or conducted.
- It is recommended that the fan providing additional air flow remain operating while the air conditioning system is powered (not just during compressor rpm). This will ensure a more efficient compressor cooling during off-cycle and longer compressor run time before any control system interventions are engaged.
- The high ambient operation assumes a typical cycling behaviour of the compressor. Constant operation at high compressor loading may cause compressor stoppage events due to overheating.

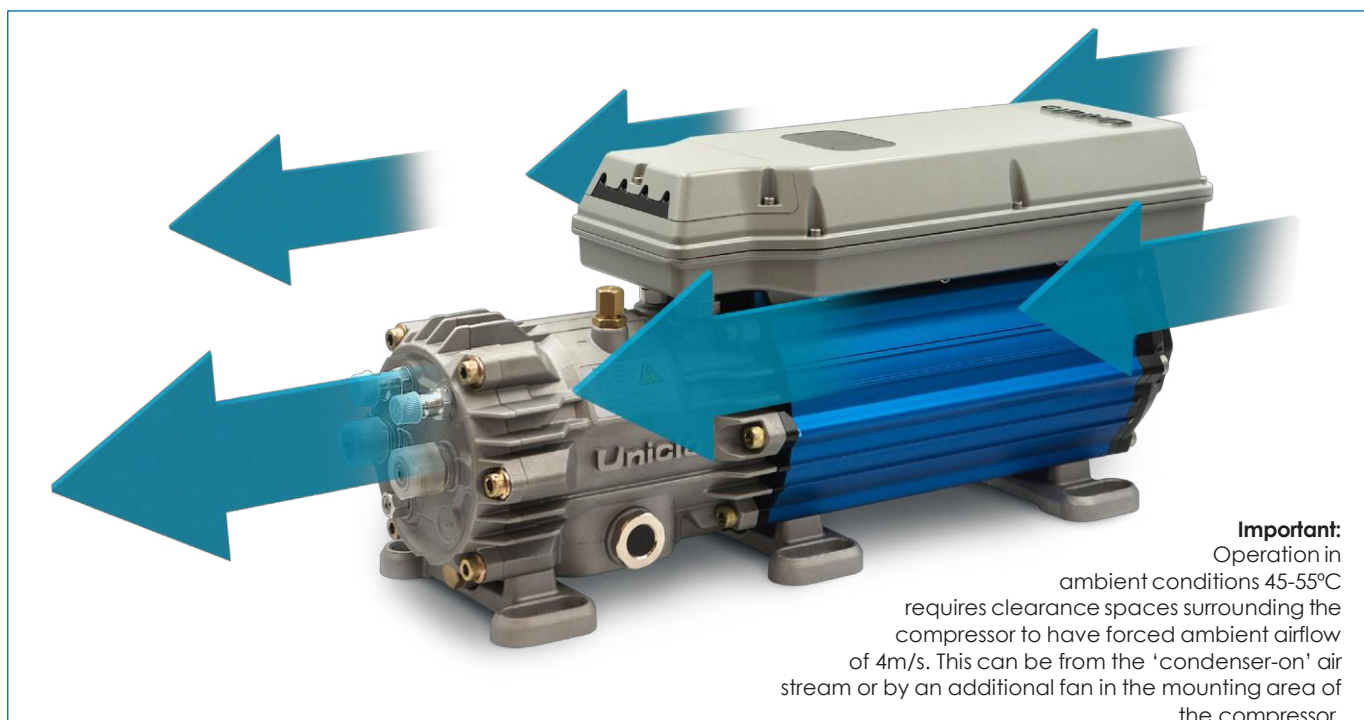

High ambient operation $\leq 55^{\circ}\text{C}$ with additional ambient airflow requirement of 4m/s

2.3 Compressor service clearance

Compressor placement should consider service access such as:

- compressor sight glass viewing
- top clearance for electrical enclosure lid removal (100mm clearance is required to open the lid)
- separation of the compressor and motor if required
- compressor removal if required
- fan access for inspection and cleaning
- service port access
- maintenance operations
- access to cable connections.

The application, install area and service tools used are different for each installation. Unicla does not recommend mandatory service clearances as there are many variables to consider.

Planning for these factors before installation will ensure a far more service-friendly unit.

3. Installation

3.1 Removing transit gas

When handling the Unicla eDrive compressor for the first time, the nitrogen holding charge must be removed prior to commissioning procedures. This can be done from the discharge service valve or hose ports (or pressure switch port if fitted). The nitrogen can be removed by slightly loosening one of the hose port caps to allow the nitrogen gas to gently escape, or if service access fittings are installed, remove one of the dust caps and depress the valve. **Note: Take care to not let oil escape.**



Remove transit gas via discharge service valve (or hose port cap). Use a small screwdriver or any tool with a pointy end to depress the Schrader valve.

Should the compressor have no pressure on arrival, pressure testing is recommended with 200psi of nitrogen to confirm pressure integrity.

3.2 Mounting surface

The compressor must be mounted on a hard level surface using the mounting tabs as shown.

Mounting requirements:

- All six mounts need contact to the mounting surface.
- In-hex screws or bolts are recommended for fastening given the tab design.
- Unicla offers an optional anti-vibration mount that interfaces with the slotted mounting tabs, making installation easier while isolating vibration.
- The oval mounting washer is a custom part that fits the mounting foot. It can be ordered separately using part number BT1025 if required

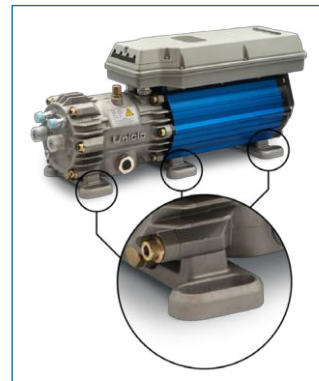

Mounting points (x6)



Optional anti-vibration mount kit
Part No. 11615-005790

3.3 Mounting angle

The compressor orientation impacts the ability of the compressor to lubricate internal components. Therefore, mounting angle limits indicated in the diagram below must be incorporated to prevent oil starvation.

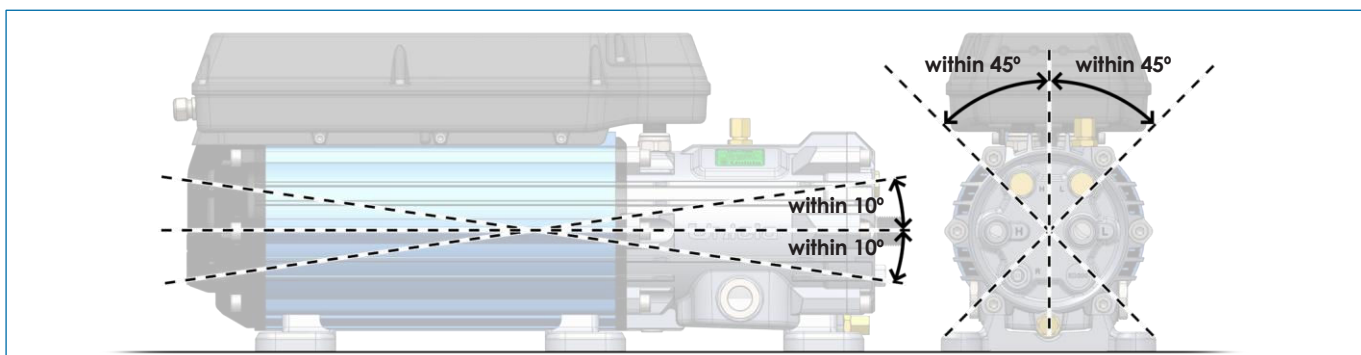

Mounting angle

4. System assembly

4.1 Contamination

The system must be free of both solid particle and chemical contamination before connecting to the compressor. Solid particle contamination will cause direct compressor damage and starvation due to

blocked system filters, screens and valves. Chemical contamination can reduce solubility or miscibility of refrigerants and oils, reduce lubrication, and cause acid etching and sludge formation.

4.2 Cleanliness during hose and manifold connection

- Assembly of all AC components including the manifold and hose connections to the Unicla eDrive compressor should be undertaken in an environment free of excessive dust and dirt, and normally suitable for standard vehicle engine compartment assembly and completion. This environment would normally meet standard occupational health and safety standards of containing $\leq 50\mu\text{g}/\text{m}^3$ concentrations of PM10 particles (particles 0.01mm in size).
- The Unicla compressor hose ports should not be opened until the hose connection procedure is completed and the system is ready for immediate evacuation. This will ensure minimal ingress of moisture and dust particles into the compressor.
- The oil in the compressor is hygroscopic and can absorb moisture from the air once exposed to ambient conditions. The contained moisture level in the oil should be kept at $\leq 50\text{ppm}$. Note: in certain ambient conditions the oil moisture content can rise to levels $\geq 500\text{ppm}$ within 15 minutes of exposure to ambient air.
- Once assembled, the complete system should have a liquid line filter drier installed, capable of filtration to ≤ 75 microns, and moisture removal of ≤ 50 ppm.

4.3 Recommended torque values

The recommended torque values in the table below should be used as a guide to ensure correct sealing of hose connections to standard Unicla hose ports. Assembly torque values for steel and aluminium O-ring hose fittings are the same due to the common sealing properties of the O-ring, and lubrication is recommended on the backside of all nuts to prevent chaffing between the nut and hose fitting tube.

The lubricant applied to any component during the hose assembly process must be the native oil used in the system.

The recommended torques are nominal torque values for industry fittings and if in doubt check with the fitting manufacturer.

Unicla hose ports	Tightening torque (Nm)		Tightening torque (Ft/lbs)	
	Steel	Aluminium	Steel	Aluminium
eDrive				
O-ring type - 7/8" - 14 UNF (#10)	21-27	21-27	15-20	15-20
O-ring type - 3/4" - 16 UNF (#8)	18-21	18-21	13-16	13-16

Hose fitting recommended torque values

5. System oil

5.1 Oil specification

Each eDrive compressor is factory charged with oil as indicated by the compressor sticker. When adding oil to the system, the correct Unica Unidap oil or a factory approved equivalent oil must be used.

Note: Mixing oil types is not permitted.

Refer to *Unicla booklet B1802 - Oil and compressor lubrication* for correct oil specifications, quantities and use in Unica compressors. **Note: Warranty is void if non-approved oils and refrigerants are used.**

Model	Refrigerant	Oil type	Label colour
UD150	R134a	UNIDAP 6 (POE)	Orange
UD150	R134a	UNIDAP 7 (PAG)	Green
UDF150	R452a	UNIDAP 3 (POE)	Blue
UDF150	R404a	UNIDAP 3 (POE)	Blue
UDY150	R1234yf	UNIDAP 9 (PAG HD46)	Yellow
UD200	R134a	UNIDAP 6 (POE)	Orange
UD200	R134a	UNIDAP 7 (PAG)	Green
UDY200	R1234yf	UNIDAP 9 (PAG HD46)	Yellow



Compressor model oil types

5.2 Oil quantity

The correct amount of oil must be maintained in the compressor and the system. Long hose runs and dual evaporator systems must have additional oil added to the system to prevent potential severe oil starvation problems.

To determine total system oil quantity Unica recommends a calculation as a percentage of refrigerant charge as follows (20% rule):

The UD150 is factory charged with 200cc of oil (COL). Therefore, to calculate the total system oil quantity (SOQ) for a UD150 connected to the system with a 2kg refrigerant charge, apply the 20% rule.

Example: Calculate oil charge as 20% of refrigerant charge – 2kg charge = 2000g x 20% = 400ml (cc) of oil. UD150 is supplied with 200cc of oil, so deduct the compressor oil charge to determine the amount of system oil to be added – therefore 400 – 200 = 200cc of oil to be added to the system.

Oil can be added to the system by filling oil into the suction line before the final hose connection or by using an oil injector during the evacuation or refrigerant charging process.

6. Oil separator

An oil separator is recommended for use with Unicla eDrive compressors in systems where the oil return to the compressor is potentially lower than it should be, at risk from a design feature in the system, or from adverse conditions created by system operation.

These can include:

- very long hose runs (>6 metres), particularly in the suction line causing pressure drop and reduced refrigerant and oil flow
- low evaporator temperatures as found in transport

refrigeration systems, causing oil to pool in the evaporator coil

- large or multiple heat exchangers providing locations for oil to pool, as found in bus and coach rooftop applications
- air conditioning systems where the condensing temperature is greater than 50°C and the evaporating temperature is lower than -5°C
- high-revving and continuous compressor operation causing excessive oil discharge from the compressor in relation to oil return.

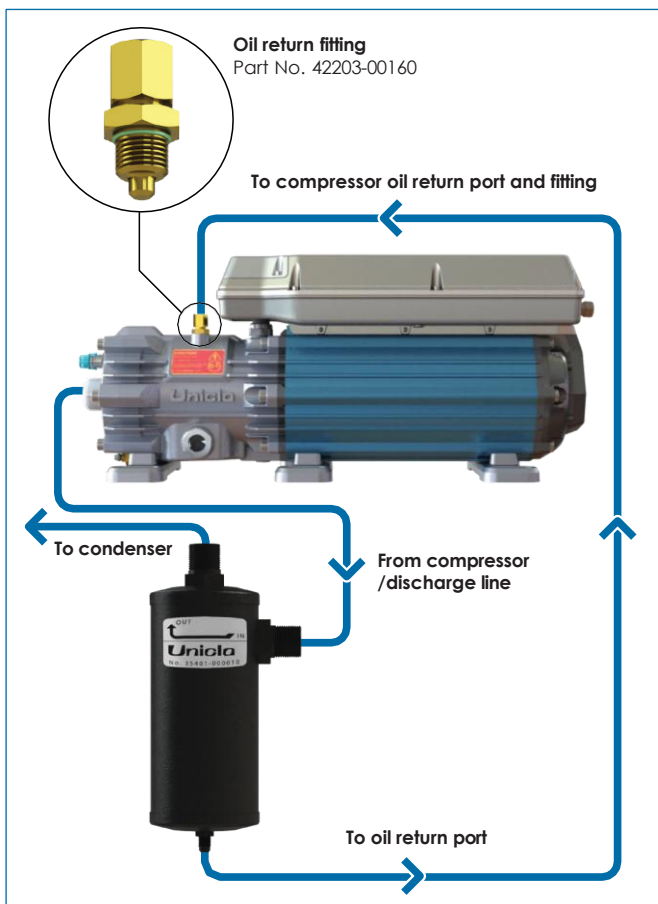

Connection options for Unicla oil separator

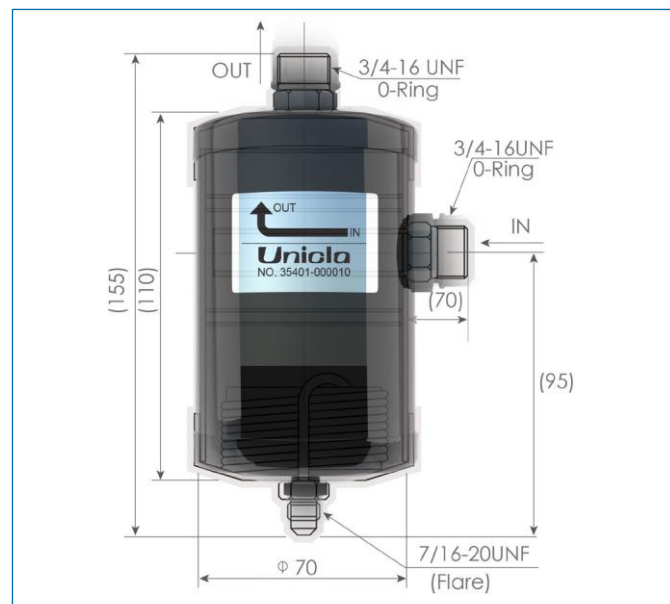

A-Type Oil Separator – Part No. 35401-000010

Oil separators are also recommended in systems where evaporator capacity is marginal and oil in the evaporator is affecting system efficiency. Reducing oil in the evaporator improves evaporator saturation temperatures by allowing optimum heat absorption in the refrigerant.

Unicla oil separators will retain >70% of the original compressor oil level (COL) or approximately 40-60% of the recommended total system oil quantity (SOQ).

A-Type Oil Separator - Part No. 35401-000010

Male insert O-ring connections (#8: 3/4-16 UNF) for easy integration in the discharge line, and a male flare (7/16-20 UNF) for the oil return line. The A-Type oil separator is ideal for use with all Unicla electric series compressors.

7. Refrigerant charging

When charging and commissioning the system for the first time, connection to the low and high side lines must be through service valves located at least 600mm distance from the compressor. This will ensure oil is not pushed or washed away from the compressor sump causing immediate damage to the compressor internal assembly during initial start-up.

Also, excessive liquid added to the system at any one time or 'bomb' charging may cause damage to the suction reed valves and piston assembly in the compressor.

It is therefore recommended that any refrigerant adding procedure should allow adequate vaporisation of the refrigerant during the process. This is commonly achieved by vapour charging only or by adding liquid very gradually to ensure no sudden removal or loss of oil in the compressor occurs.

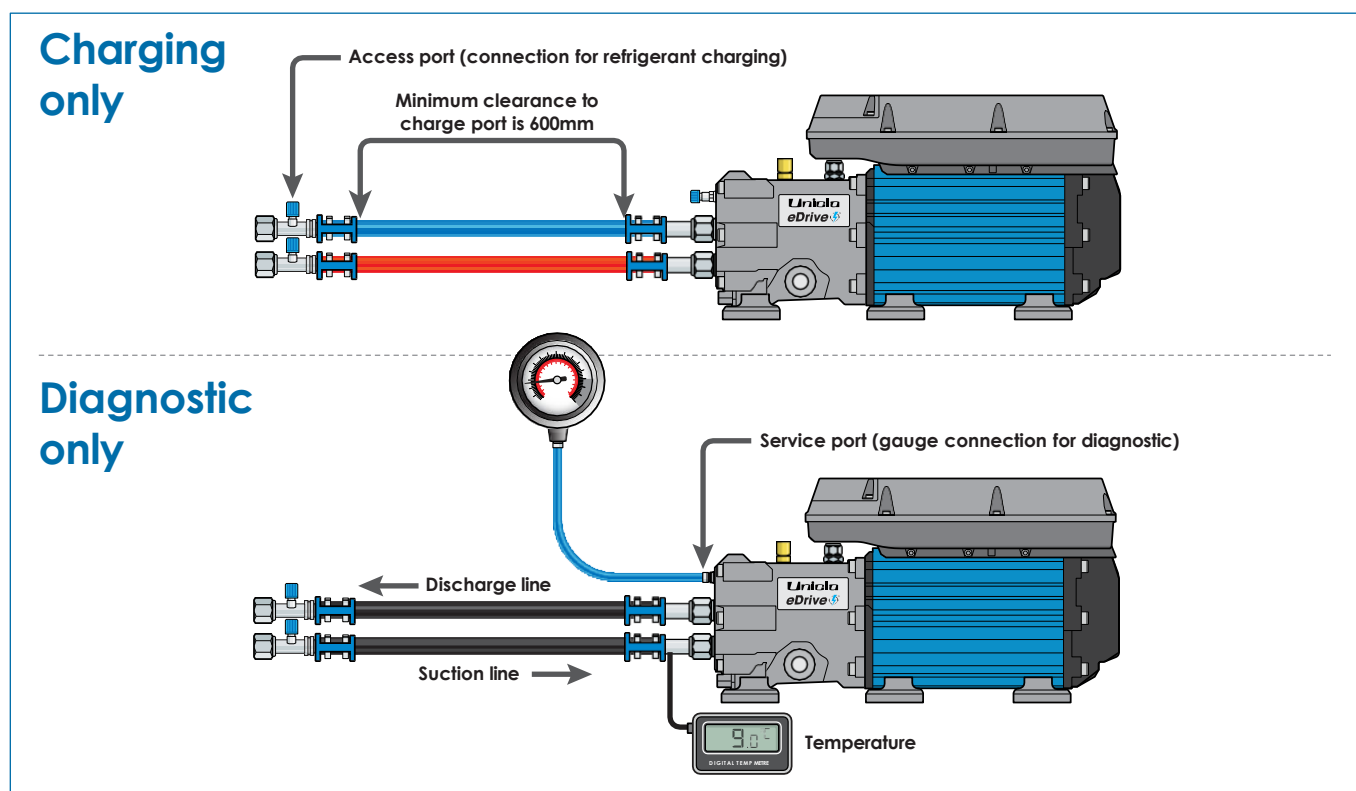

Refrigerant charging and diagnostic access points

8. Compressor electrical connection

8.1 Unicla electrical fly lead

The eDrive is typically supplied with a fly lead for electrical connection.

The fly lead is pre-terminated inside the electrical enclosure for installation convenience. The tail wires are colour coded as follows.

BLACK	0Vdc
RED	POS Vdc
GREEN/YELLOW	Earth / Chassis bond

Incoming voltage and polarity must be checked and confirmed before energising. Incorrect polarity may cause damage to the PCBA.



Unicla standard fly lead

Supply cabling specifications from the power supply to the fly lead should meet or exceed the current draw at the rated maximum power input, and the maximum supply voltage drop to the unit should be <2%.

Please note:

All electrical work may be carried out only by suitably qualified and competent persons in accordance with national and local safety regulations. All electrical work carries a risk of death or serious injury.



8.2 Variation – Unicla fly lead not factory fitted

Should the eDrive be ordered and supplied without a Unicla fly lead, the electrician installer will need to access the internal area of the electrical enclosure.

This area is fragile and electrostatically sensitive, therefore extreme care must be taken working in this area.

Supply cabling specifications from the power supply to the compressor should meet or exceed the current draw at the rated maximum power input, and the maximum supply voltage drop to the unit should be <2%.

Please note:

All electrical work may be carried out only by suitably qualified and competent persons in accordance with national and local safety regulations. All electrical work carries a risk of death or serious injury.



The electrical enclosure is mounted onto the body of the DC brushless motor. The main lid is retained by six screws with a small lid covering communication cable sockets retained by three screws. The base

is cast with integral cooling fins which interlock with cooling fins on the brushless sensorless DC motor to provide essential cooling to the motor and electrical enclosure.

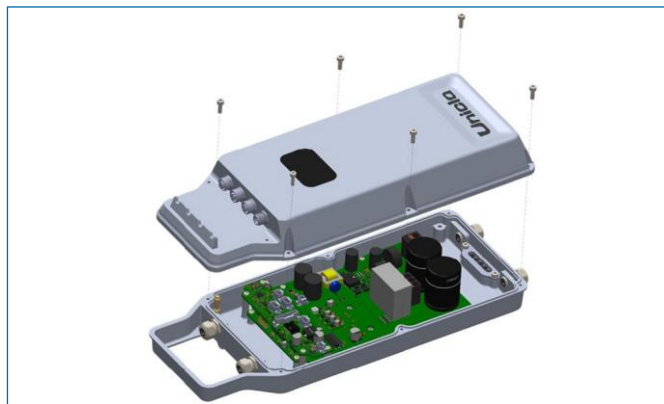

8.3 Electrical enclosure access

To access the control board area:

- isolate Vdc electrical supply if already energised
- allow five minutes before opening the enclosure for the capacitors to discharge and confirm residual voltage is safe by multimeter
- remove the six screws retaining the lid
- find a box of similar height to the base height and place beside the motor
- carefully lift the lid upward noting that there is a communications cable and earth connecting the base and lid together
- roll the lid over onto the box which acts as a support.

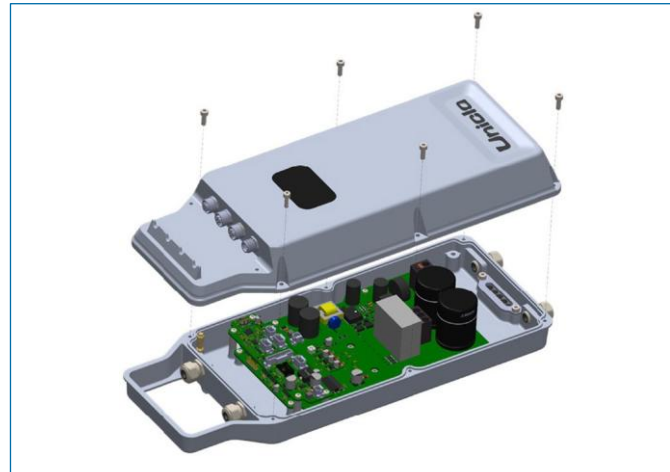

Electrical enclosure (controller housing) access

8.4 Electrical connection

To complete the connection:

- confirm the Vdc supply is isolated
- fit the supply cable with bootlace crimps and ring terminal on the earth wire
- insert the voltage supply cable through the enclosure gland and insert the bootlaces into the corresponding terminal
- connect the incoming earth wire to the earth lug by eyelet connector with M5 screw head cap screw and spring washer (an earth wire must be connected)
- confirm the correct polarity of the connection otherwise compressor PCB damage is possible
- validate that all internal cable connectors and transducer sockets are pushed in securely
- check gland tightness and refit lid ensuring no cables are pinched or conflicted with internal components.



Lid resting on temporary box

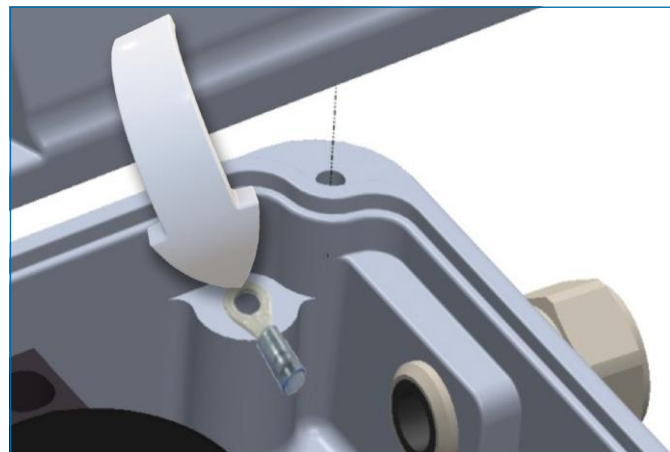

Earthing point

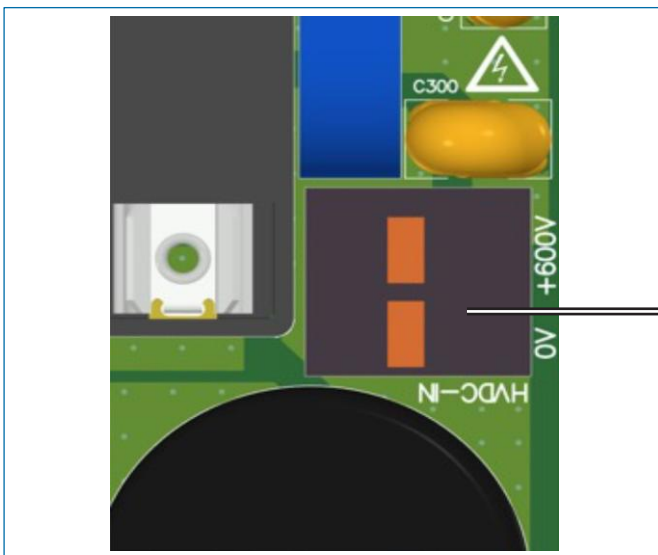

Vdc connection

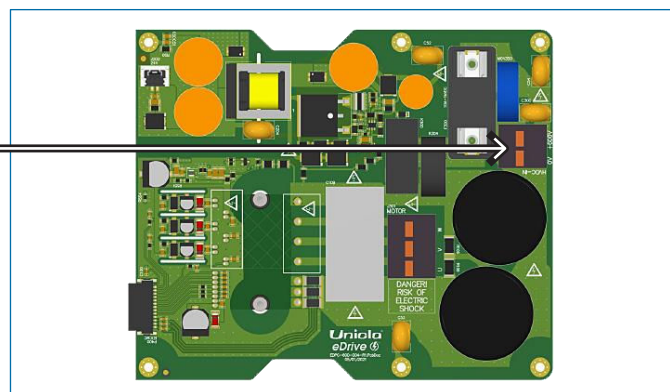

9. Cable options

When ordering the Unicla eDrive compressor, the optional cabling solutions can be selected according to the intended connection and control plan. This provides flexibility and customisation to meet the needs of the project.

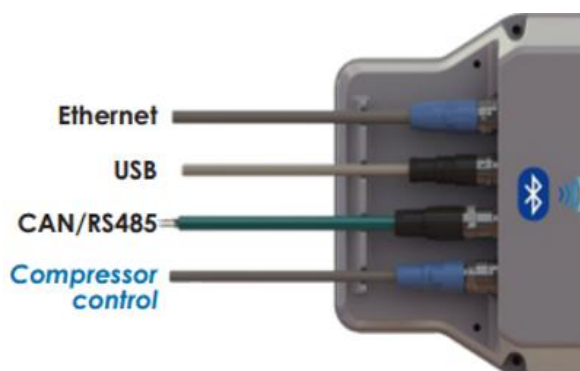

eDrive to USB Part No. 50402-001100

Suited to standard temporary fitment applications as there is no cover on the USB end.

A 1.5m cable is included. USB is suited to applications where environmental electronic noise is low. Noise will affect communication stability.

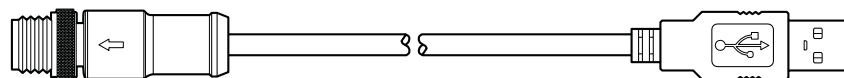

eDrive to USB (fixed mount bracket) Part No. 50402-001170

Suited to applications where accessibility is poor, and a permanent fixed remote communication port would be advantageous. A 1.5m eDrive cable with sealed screw-on cover is included. The mounting bracket is stainless.

USB A to USB B cable suits a laptop connection. USB is suited to applications where environmental electronic noise is low. Noise will affect communication stability.

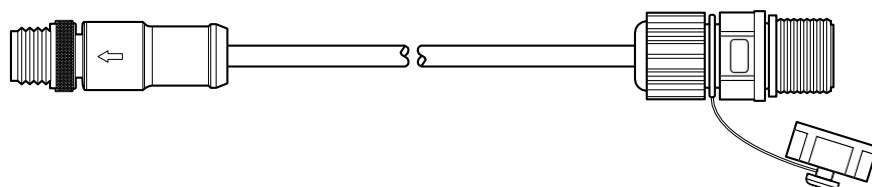

eDrive to ethernet RJ45 Part No. 50402-001120

Suited to applications where environmental noise exists. A 2.0m ethernet eDrive cable is included.

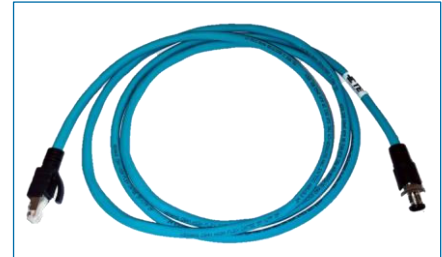
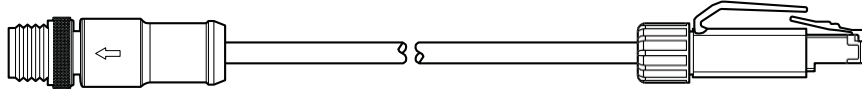

eDrive to CAN / RS485 Part No. 50402-001130

A 3.0m open ended cable for site termination is included.

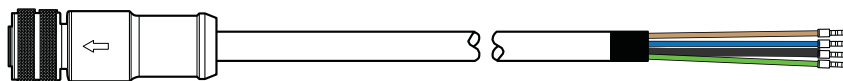

P1	Wire list	Function
PIN 3	black	GND
PIN 4	brown	CAN-H/R485-A
PIN 5	blue	CAN-L/R485-B
SHELL	braid + yellow / green wire	SHIELD



eDrive control with integrated 4P Deutsch plug (fault output not supported) Part No. 50402-001190

Simplifies the install by incorporating a pre-terminated Deutsch plug. The installer can use the supplied mating kit to terminate with their site control wires. The plug configuration provides for fixed speed/run, variable speed, variable speed + remote enable (0-10Vdc, 4-20mA).

A 1.0m eDrive cable with Deutsch plug fitted is included. A mating Deutsch plug kit must be crimped on site by the installer. While the cable is shielded, the Deutsch plug is not. The cut end solution is recommended for high noise / EMC environments.

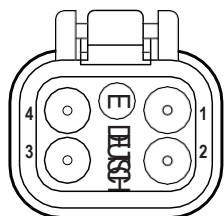
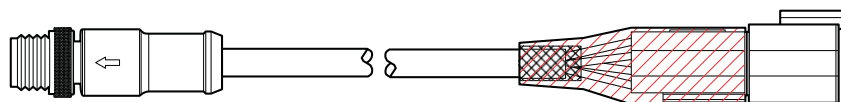

- Position 1: 0 V/GND
- Position 2: RUN
- Position 3: 0-10V
- Position 4: 4-20 mA



eDrive control cut end (finned connections) Part No. 50402-001250

A 5.0m open ended control cable is included.

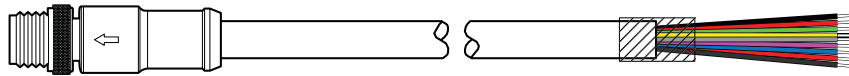

Pin No.	Wire colour	Function	Polarity
Pin 1	White	Zero volts	Ground
Pin 2	Brown	10 Vdc output	Positive
Pin 3	Green	Compressor fault output	
Pin 4	Yellow	RUN/remote enabled	Positive
Pin 5	Grey	Zero volts	Ground
Pin 6	BLACK	4-20mA variable speed	Positive
Pin 7	Blue	0-10Vdc variable speed	Positive
Pin 8	RED	Zero volts	Ground
Housing	Black	Shield wire (black heat shrink)	N/A

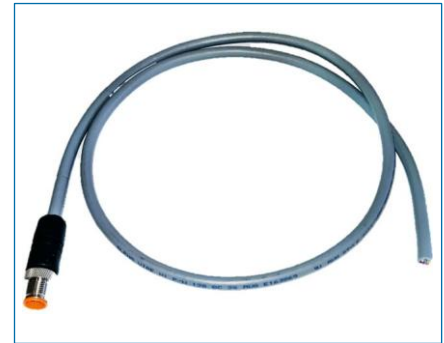

Please note that many environments such as electric trucks and their power systems have extreme EMC or electronic noise output. In extreme cases the control functionality may corrupt. We suggest connecting the shield wire to a suitable grounding surface such as the metal condensing unit case for double end shielding.

Using the M12 cable connections

Unicla compressors use M12 series connectors for the four communications cables. Each cable has a specific key that suits only one communications port. Some important considerations are

- Confirm the required port using the lid sticker
- Match the correct cable for the port (e.g. Ethernet cable (M12) to eDrive ethernet port)
- Before inserting the cable, review the pin and key arrangement to ensure the plug is correctly oriented
- Ensure the plug is aligned correctly with the socket and the pins align correctly
- Push the plug into the socket until there is thread engagement, then screw in hand tight
- **An important consideration for the compressor install** is the access to the M12 ports. The communications cover must have enough clearance to be removed (3 screws). There must sufficient clearance to access the ports which are delicate and require some fine positioning to successfully insert the plug.
- A minimum 100mm clearance is recommended above the lid to allow for lid removal and port access for hand tightening
- The M12 plugs should only be finger tightened
- It is possible to damage the M12 port and or cable should it be forced or inserted incorrectly
- Refit the protective caps if the cable is removed to prevent dust and moisture entry



10. Integrated motor load protection

Integrated motor safety: Nominal 3000W motors (UD150)

Maximum continuous power consumption is 4.0kW. If this is exceeded for a continuous period of 10 seconds, the motor is stopped, and a restart is attempted following an idle period (typically two minutes).

If power consumption exceeds 4.5kW, the motor is immediately stopped, and a restart is attempted following an idle period (typically two minutes). The number of restarts is limited, after which operator intervention is required.

Integrated motor safety: Nominal 4500W motors (UDF150, UD200)

Maximum continuous power consumption is 5.0kW. If this is exceeded for a continuous period of 10 seconds, the motor is stopped, and a restart is attempted following an idle period (typically two minutes).

If power consumption exceeds 5.5kW, the motor is immediately stopped, and a restart is attempted following an idle period (typically two minutes). The number of restarts is limited, after which operator intervention is required.

Refer to the model specific *Motor Information technical bulletin* for further detail

11. eConnect app

The primary communication interface for eDrive is eConnect which is available from the Unicla.hk website or via this download link <https://hub.unicla.hk/econnect/>. eConnect is available only to windows-based systems and connects via ethernet or USB. The username and password is *admin* (lower case). Please adjust the windows display scale to 100%.

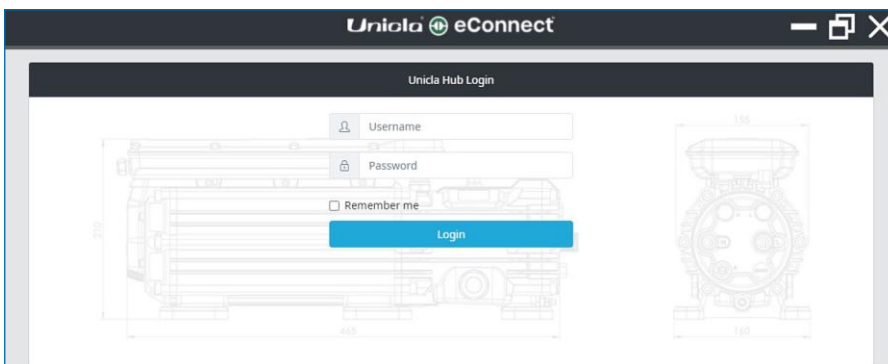

eConnect login interface

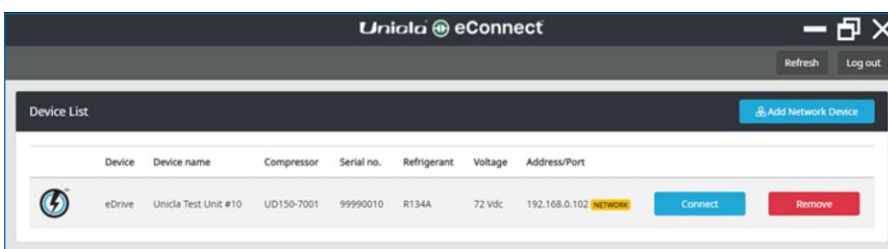

eConnect found devices after refresh

Power on the compressor and connect eDrive via ethernet or USB. There may be a residual device showing depending on previous connections that may not result in a successful connection. Press *refresh* to find current connected devices with their current address detail. Press *connect* on desired device/connection type. Note there could be multiple devices and connection types available depending on your network and connections.

If the compressor cannot be discovered in eConnect, first confirm that the compressor is electrically connected and powered on by the nominated voltage. Double check that the communications cable (Ethernet or USB) is pushed into position and hand screwed tight onto the compressor communication connections.

For USB:

- try removing and re-inserting the USB connector
- try an alternate USB connection on the computer
- try a restart of the computer.

For Ethernet:

- confirm an active network exists on the ethernet port
- confirm that there are no virus scan programs blocking access or ports being denied access (UDP port 5353)
- try to plug the cable directly into the ethernet port on the computer rather than over a network
- if a static IP address has been created, a device can be manually added to the device list.

Please note that many environments such as electric trucks and their power systems have extreme EMC or electronic noise output. USB may become corrupt in these environments causing disconnects. Use of the ethernet connection is recommended where noise is a factor.

11.1 Dashboard

Once there is successful connection and an eDrive is selected, the eConnect will navigate to the dashboard. The dashboard displays current pressures, temperatures and system status for nearly all eDrive metrics.

The top right of the screen has a *Log to file* button that can save all parameters to a .CSV file for later analysis if required. Press *Log to file* and select the file location, then press the button again to end logging.

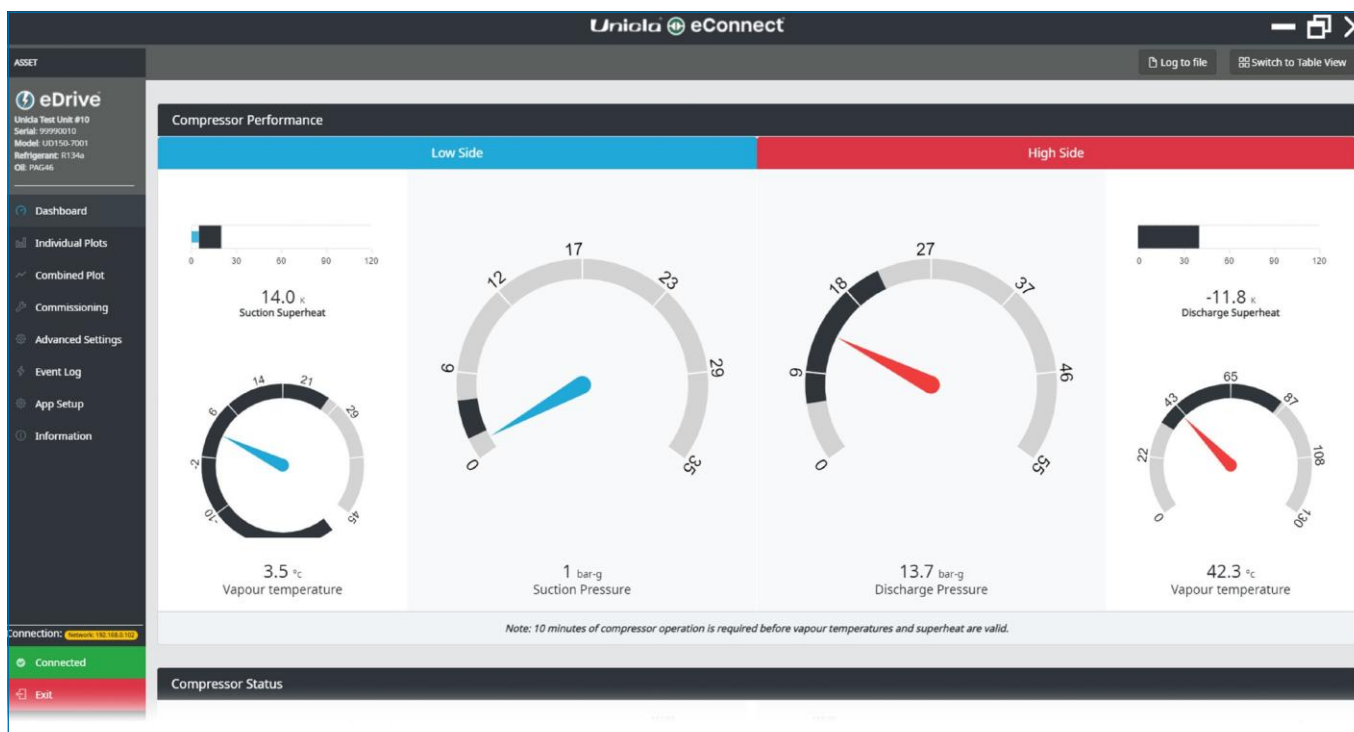

eConnect dashboard for selected device

11.2 Dashboard – compressor performance

The compressor performance bar displays a refrigerant gauge view providing the technician with a traditional system overview. As an alternative the user can select to view the information in tabular format by selecting **Switch to table view** in the top right-hand side.

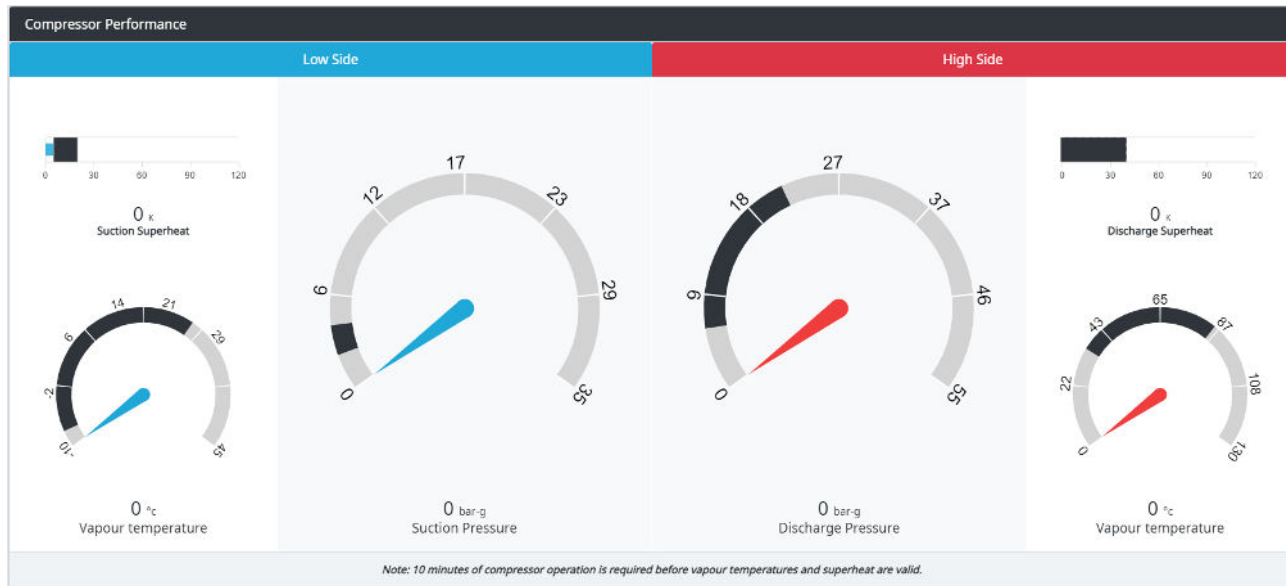

11.3 Dashboard – compressor status

The compressor control status bar provides an operational snapshot of the connected eDrive.

The **status cell** provides a compressor status message for the operator as outlined on page 19.

The **compressor control setting** cell is a visual confirmation of the of the control setting as set up in commissioning.

The **remote enable signal** cell is a visual confirmation if the eDrive is receiving a remote enable signal from an external source such as the thermostat. When it is green, there is a signal present and depending how the compressor is configured will enable or start the compressor.

The **thermostat demand** cell is a dashboard indication of the variable speed demand for eDrive based on the incoming control signal and the commissioned parameters for variable speed

The **anti-short cycle** timer gives the user a reference of the remaining time-out to allowing the next start sequence based on the commissioned settings.

The **eConnect Control bar** provides 2 key functions. If the user wants manual control (eConnect control) this will allow a dashboard located start / stop function. Should eDrive be running in a fixed or variable mode, pressing stop will stop the compressor and revert the compressor control setting to eConnect control. The eConnect control setting can be reversed back to fixed / variable control in the commissioning tab when required.

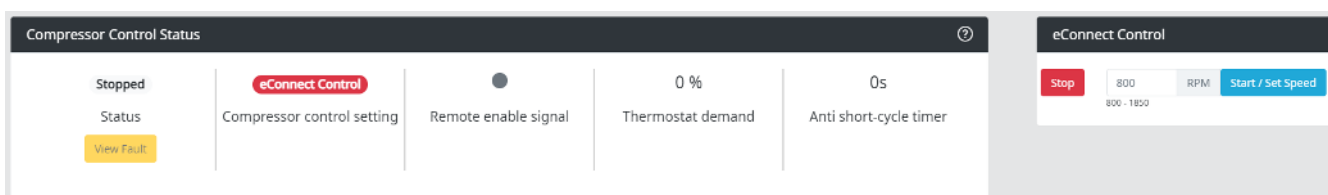

eConnect compressor status

11.4 eConnect app menu

The app is largely intuitive in nature with menu structure outlined below.

The screenshot shows the eDrive app menu with the following items and their descriptions:

- ASSET**: Unica Test #10, Serial: 99990010, Model: UD150-7001, Refrigerant: R134a, Oil: PAG46. *Details of the connected device*
- Dashboard**: *Navigate to the dashboard (primary information display)*
- Individual Plots**: *View single element logged data (since app connection initiated)*
- Combined Plot**: *View combined element logged data (since app connection initiated)*
- Commissioning**: *Compressor operation set up*
- Advanced Settings**: *Additional feature set up*
- Event Log**: *View event record (since app connection initiated)*
- App Setup**: *App settings*
- Information**: *General and statistical information*

11.5 eConnect commissioning

The commissioning is split into three separate sections:

- control function - motor settings
- user level operational limits - compressor run settings
- oil balance control

The screenshot displays the Commissioning section of the eDrive app, divided into three sub-sections:

Motor Settings

- Compressor Control Type: eConnect Control
- Control Input: 0 - 10 Volts
- Remote Enable: Off
- Ramp Speed Rate of Change: 200 RPM/s
- Anti Short Cycle - Time Before Restart: 60 s
- Valid Settable Speed Range: 800 - 1850 RPM

Compressor Limits Settings Run

LOW SIDE	Low cut-out	High cut-out	HIGH SIDE	Low cut-out	High cut-out
Pressure (bar-g)	0.5 (Range: 0 to 3)	3 (Range: 2 to 5)	Pressure (bar-g)	5 (Range: 4 to 9)	21 (Range: 10 to 25)
Temperature (°C)	-30 (Range: -10 to 35)	25 (Range: 0 to 45)	Temperature (°C)	35 (Range: 25 to 50)	85 (Range: 75 to 100)
Superheat (°C)	5 (Range: 3 to 15)	20 (Range: 10 to 30)	Superheat (°C)	-40 (Range: -10 to 40)	40 (Range: 10 to 50)

Oil Balancing

Run At Next Power Up: Off

Trigger Time (Hours Idle): 24 Hours (Range: 1 to 48)

RPM: 800 (Range: 800 to 1850)

Run Oil Balance

Cycle	Run (s)	Stop (s)
1	10 (Range: 10 to 30)	10 (Range: 10 to 60)
2	10 (Range: 10 to 30)	10 (Range: 10 to 60)
3	10 (Range: 10 to 30)	10 (Range: 10 to 60)
4	0 (Range: 10 to 30)	0 (Range: 10 to 60)

11.6 Control function - motor settings

The motor settings tab provides cells for various compressor control configurations. eConnect control is a manual control via the dashboard (stop, start, rpm setting) and is useful for commissioning, testing and diagnosis. Always ensure the system is active before using this feature (fans on/ valves open).

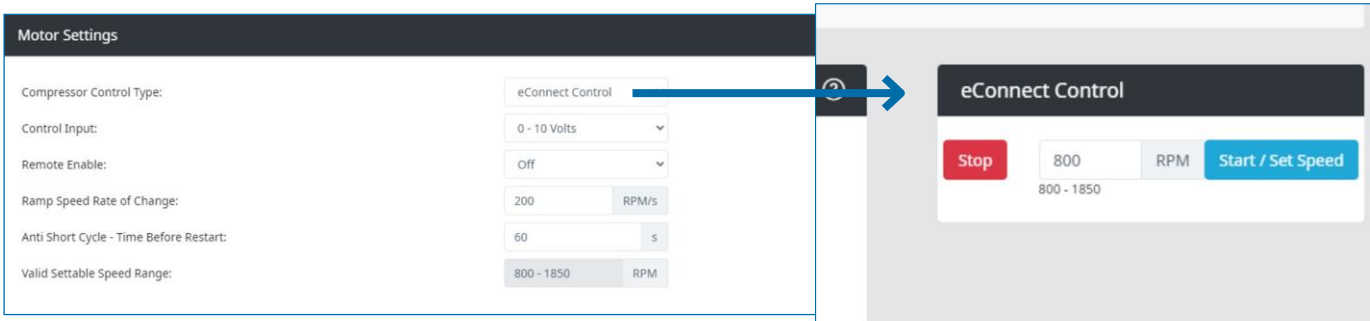

Other points about eConnect

- Fixed speed/run is traditional on/off control via thermostat or other signal (10-24Vdc).
- Control input and remote enable are not configurable in this control type.
- Ramp speed allows some control of speed changes.
- Anti short cycle timer adds a configurable delay between stop and start.



- Variable speed allows speed control based thermostatic demand outputting 0-10Vdc or 4-20mA.
- Control input allows specification of the thermostatic output.
- Remote enable/run takes a 10-24Vdc input to act as a gate to operate regardless of demand.
- Ramp speed allows some control of speed changes.
- Anti short cycle timer adds a configurable delay between stop and start.
- Speed max/min allows a speed range to be set with the corresponding input signal.

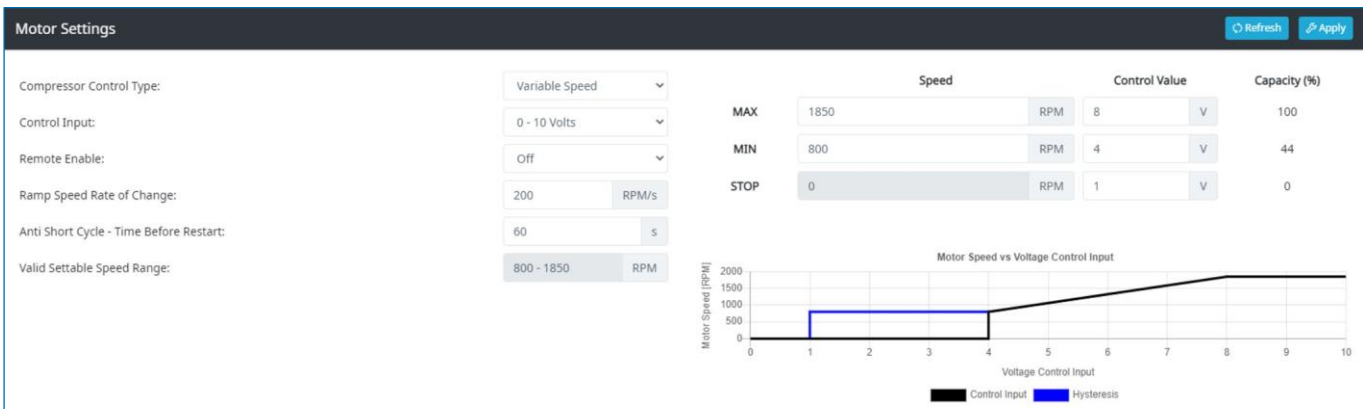

Note: Should a change be required, amend the parameter then press **Apply**. **Refresh** will pull the current setting from the eDrive. (This is a default sequence for change within the app).

11.7 User level operational limits - compressor run settings

eDrive compressors include a preconfigured range of operational limits that will suit most applications. These limits are applicable to the compressor only when it is running, and do not apply to the safety limits of starting the compressor. The limits can be adjusted to a specific application within the ranges indicated in the table below by changing the parameter and pressing apply. It is recommended this task is completed at the initial commissioning of the system if the standard Unicla settings are to be re-configured,

Compressor Limits Settings Run								Refresh	Apply
LOW SIDE				HIGH SIDE					
	Low cut-out		High cut-out		Low cut-out		High cut-out		
Pressure (bar-g)	0.5	Range: 0 to 3	3	Range: 2 to 5	Pressure (bar-g)	5	Range: 4 to 9	20	Range: 10 to 25
Temperature (°C)	-7.5	Range: -10 to 35	25	Range: 0 to 45	Temperature (°C)	35	Range: 25 to 50	85	Range: 75 to 100
Superheat (K)	5	Range: 3 to 15	20	Range: 10 to 30	Superheat (K)	-20	Range: -30 to 40	40	Range: 10 to 50

As an example of the function is as follows.

The **Low side pressure** low cut out range in this case below can be set between 0-3 bar. If you set this to 0.5 bar then it will fault at 0.5 bar or lower

The **Low side pressure** high cut out range in this case below can be set between 2-5 bar. If you set this to 3 bar then it will fault at 3 bar or higher

Therefore, the effective operating range of the compressor is in between these two points. 0.5 and 3.0 bar.

LOW SIDE	Low cut-out		High cut-out	
Pressure (bar-g)	0.5	Range: 0 to 3	3	Range: 2 to 5
Temperature (°C)	-7.5	Range: -10 to 35	25	Range: 0 to 45
Superheat (K)	5	Range: 3 to 15	20	Range: 10 to 30

The **High side pressure** low cut out range in this case below can be set between 4-9 bar. If you set this to 5 bar then it will fault at 5 bar or lower

The **High side pressure** high cut out range in this case below can be set between 10-25 bar. If you set this to 20 bar then it will fault at 20 bar or higher

Therefore, the effective operating range of the compressor is in between these two points. 5 and 20 bar.

HIGH SIDE	Low cut-out		High cut-out	
Pressure (bar-g)	5	Range: 4 to 9	20	Range: 10 to 25
Temperature (°C)	35	Range: 25 to 50	85	Range: 75 to 100
Superheat (K)	-20	Range: -30 to 40	40	Range: 10 to 50

11.8 Oil balance control

Unicla has developed a configurable, embedded oil balance system (OBS) which is a feature incorporated into the compressor control logic as an additional layer of protection for the compressor.

Systems which have been dormant for extended periods without operation have the potential to accumulate liquid refrigerant in the evaporator and suction line sufficient to cause oil washout of the compressor sump during start. This phenomenon can also occur during initial commissioning of new systems.

The oil balance system forces a staggered start after the defined period of compressor dormancy (no rpm) to help pass any migrated refrigerant thereby reducing oil washout.

The OBS parameters are available in the commissioning page of eConnect. The default factory configured on/off timings suit most applications, however the OBS is highly configurable. If a system is considered susceptible to refrigerant migration, it is recommended to decrease the time to OBS activation and maintain an OBS compressor rpm as low as possible suitable to the application.

Additional characteristics

- Run at next power-up allows for forced OBS next power-on after power-off.
- Trigger time is the dormant time (no rpm) to next OBS.
- The rpm is the specified compressor rpm for OBS cycle only.
- Run oil balance is a function to force an OBS cycle.
- The number and length of each cycle is configurable.
- The OBS cannot be stopped once started.

The screenshot shows the 'Oil Balancing' dashboard with the following configuration options:

- Run At Next Power Up: OFF
- Trigger Time (Hours Idle): 1 Hours (Range: 1 to 48)
- RPM: 800 RPM (Range: 800 to 1850)
- Buttons: Run Oil Balance, Refresh, Apply

The cycle table is as follows:

Cycle	Run (s)	Stop (s)
1	14 (Range: 10 to 30)	16 (Range: 10 to 60)
2	14 (Range: 10 to 30)	16 (Range: 10 to 60)
3	14 (Range: 10 to 30)	16 (Range: 10 to 60)
4	0 (Range: 10 to 30)	0 (Range: 10 to 60)
5	0 (Range: 10 to 30)	0 (Range: 10 to 60)

Typical OBS status on the dashboard

Note: Should a change be required, amend the parameter then press **Apply**. **Refresh** will pull the current setting from the eDrive. (This is a default sequence for change within the app)

11.9 Information tab

The information page provides an overview of system details and statistics .

Firmware information		System operation information	
CMC Firmware Version	4.0.2	First Run	2000-01-01 10:17
FMC Firmware Version	4.0.0	Run time	0 Days 16 Hours 21 Minutes
EDXC Firmware Version	4.0.2	Energised time	0 Days 21 Hours 57 Minutes
eConnect Version	3.0.0	Time Since Last Stop	0 Days 20 Hours 49 Minutes

- The **device name** can be changed within the device name cell. Update the name and press apply.

The screenshot shows the 'Hardware information' page with the following details:

- Buttons: Refresh, Apply
- Model: UD150-5001
- Device Name:
- Serial number: 40615220005
- Manufacture date: 14 August 2025

12. Adaptive control

12.1 Introduction

eConnect includes adaptive control which provides a range of discreet control modules that adapt to changing environmental conditions providing control and protection functionality. Adaptive control uses sensor measurement and commissioned inputs to modulate compressor RPM and control system behavior. It is accessed within the Advanced settings tab.

The modules and their functionality are summarized in table 1

Control module	Control type	Parameter	Activation	Typical application
High side pressure protection	limit	Pressure high side	When triggered	Managing RPM to avoid fault
Low side pressure protection	limit	Pressure low side	When triggered	Managing RPM to avoid fault
Power consumption protection	limit	Power	When triggered	Managing RPM to avoid fault
Low side pressure control	set point	Pressure low side	Always	Managing RPM to maintain suction pressure

To activate Adaptive control, go to advanced settings >> adaptive control >> enable. Once enabled, three confirmation cells will become active allowing them to be enabled discreetly.

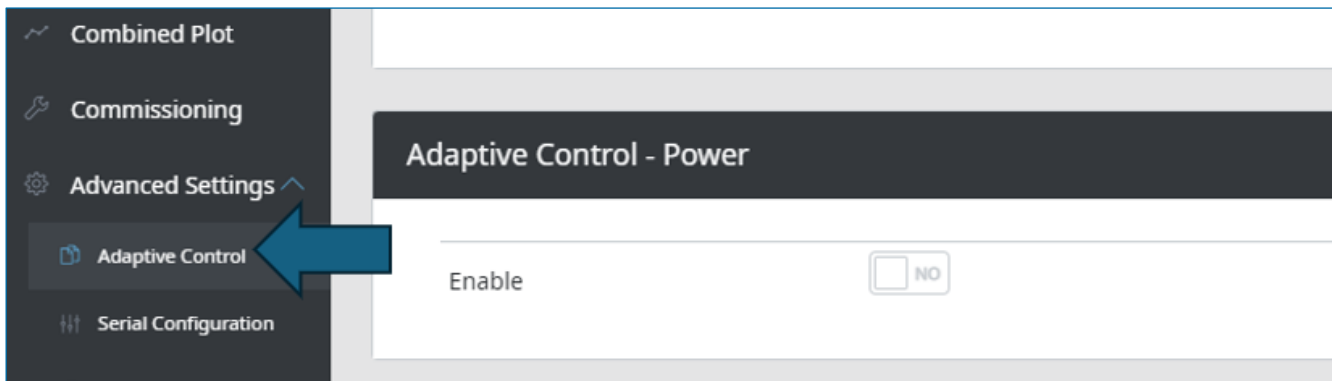

12.2 Adaptive control – Discharge protection

A range of discharge limits are available in the commissioning page to set operational fault points for pressure. If the system exceeds these limits; the system will fault and stop. This may occur due factors such as an extreme ambient temperature event, operational variability, system issue or condenser obstruction.

Typically lowering compressor speed lowers total heat of rejection required and would avoid fault within the RPM range available. The Unicla discharge protection acts to manage RPM once enabled then triggered, keeping the high side pressure within the specified high side pressure limit and within the available range of RPM.

The trade off with discharge protection intervention is that it lowers cooling capacity and ultimately increases suction pressure. The objective of discharge protection is to extend operation rather than faulting while maintaining compressor safety. Once there is no more RPM turn down, fault mode is inevitable.

The graph below provides a snapshot of standard operation vs discharge protection looking at RPM and high side pressure.

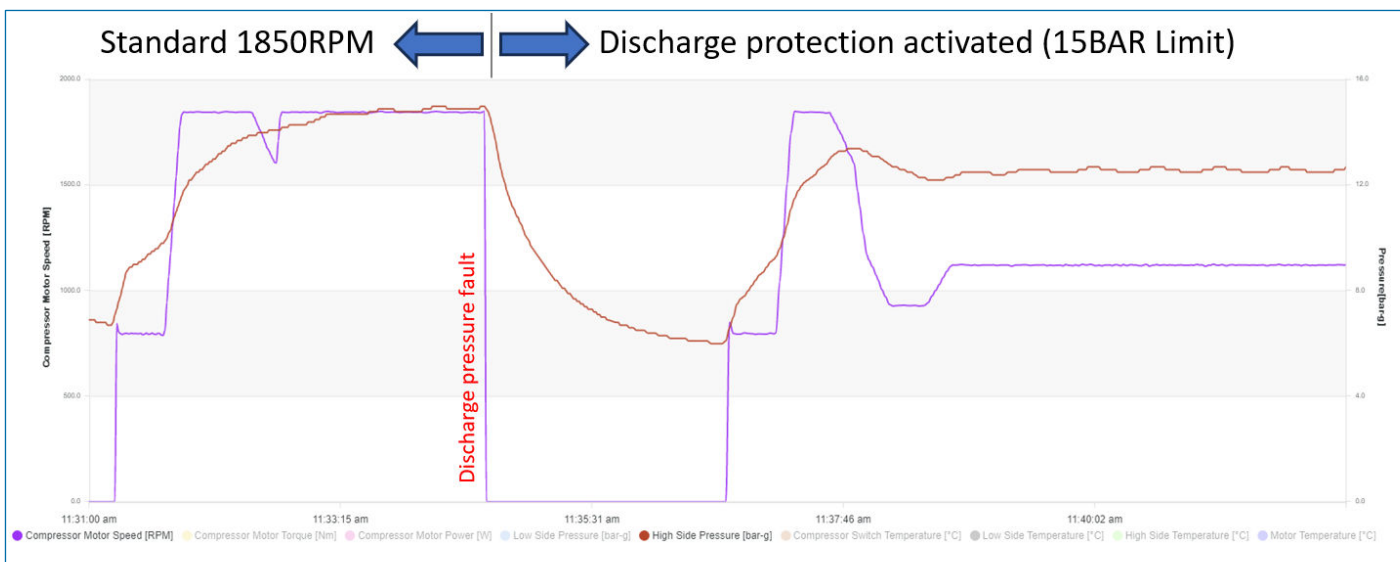

The discharge pressure commissioning tab includes factory settings that will suit most applications however the commissioner can make a change as required to suit a specific installation.

- **Enable:** Activate discharge protection.
- **Correction band:** defines range of intervention.
- **Calculated setpoint:** displays current intervention start point based on limit setting
- **Start up speed:** enables a 'soft start' which can be useful for general operation.
- **Start up speed RPM:** sets the start up RPM value .
- **Start up speed time:** defines the 'soft start' duration.

Adaptive Control - Discharge Pressure				Refresh	Apply
Enable	<input checked="" type="checkbox"/>	Advanced	<input type="checkbox"/>		
Correction Band (%)	15	%	Range: 10 to 50	Calculated Setpoint	17.2 bar-g
Startup Speed Limiting	<input checked="" type="checkbox"/>				
Startup Speed	800	RPM	Range: 800 to 1850		
Startup Time	30	S	Range: 5 to 300		

The advanced tab can be enabled which opens a far wider set of parameters to change discharge pressure protection behavior. We recommend the simple interface for most users. The advanced tab is only useful for smoothing control outcomes if required.

12.3 Adaptive control – Suction protection

A range of suction limits are available in the commissioning page to set operational fault points for pressure. If the system exceeds these limits; the system will fault and stop. This may occur due factors such as a low gas charge, low ambient conditions or evaporator obstruction.

Typically lowering compressor speed raises low side pressure and would avoid fault within the RPM range available. The Unicla suction protection acts to manage RPM once enabled then triggered, keeping the low side pressure within the specified pressure limit and within the available range of RPM.

The trade off with suction protection intervention is that it lowers cooling capacity. The objective of suction protection is to extend operation rather than fault while maintaining compressor safety. Once there is no more RPM turn down, fault mode is inevitable.

The graph below provides a snapshot of standard operation vs suction protection looking at RPM and low side pressure.

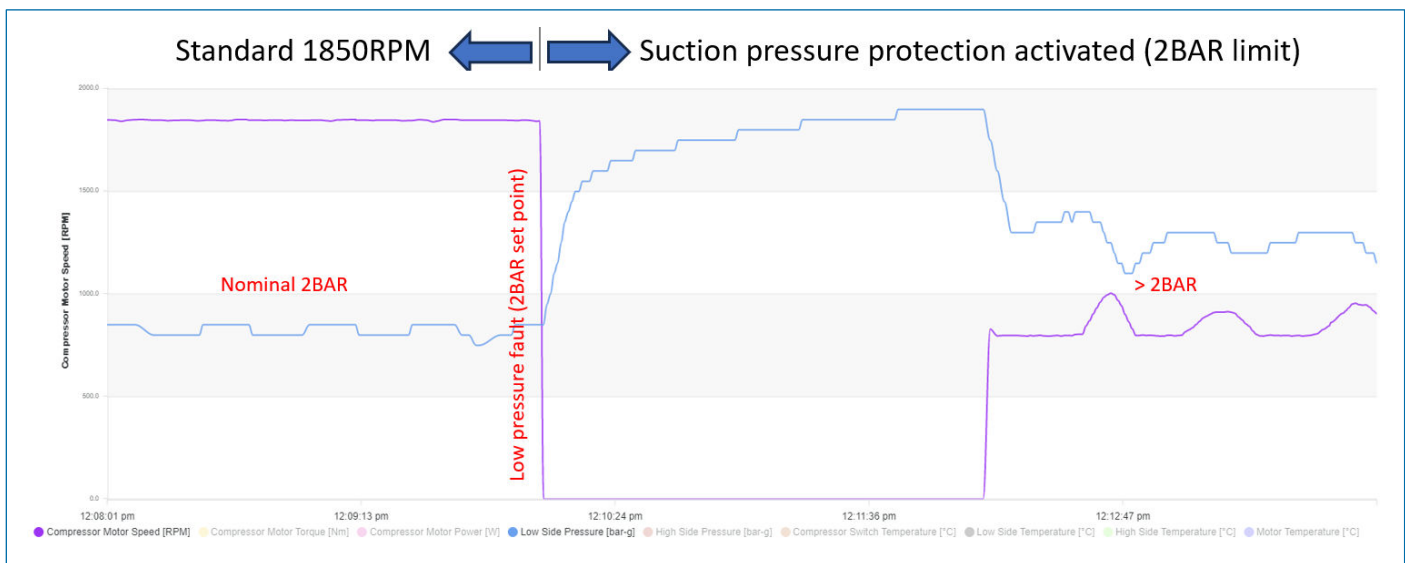

The suction pressure commissioning tab includes factory settings that will suit most applications however the commissioner can make change as required to suit their installation.

- **Enable:** Activate suction protection.
- **Correction band:** defines range of intervention.
- **Calculated setpoint:** displays current intervention start point based on limit setting
- **Start up speed:** enables a 'soft start' which can be useful for general operation.
- **Start up speed RPM:** sets the start up RPM value .
- **Start up speed time:** defines the 'soft start' duration.

Refresh Apply

Adaptive Control - Suction Pressure

Enable	<input checked="" type="checkbox"/>	Advanced	<input type="checkbox"/>
Mode	Protect	<small>Suction Pressure Control is only available in Fixed Speed Mode</small>	
Correction Band (%)	18	Range: 10 to 50	Calculated Setpoint: 2.8 bar-g
Startup Speed Limiting	<input checked="" type="checkbox"/>		
Startup Speed	800	RPM	Range: 800 to 1850
Startup Time	30	S	Range: 5 to 300

The advanced tab can be enabled which opens a far wider set of parameters to change discharge pressure protection behavior. We recommend the simple interface for most users. The advanced tab is only useful for smoothing control outcomes if required.

12.4 Adaptive control – Power protection

This is a configurable function to limit eDrive power consumption by management of the compressor RPM. Often the battery power available in electric vehicles and machinery has its own limitations. If the battery or inverter limits are exceeded; the component will fault and stop.

The Unicla adaptive control-power protection acts to manage RPM by keeping the power below the specified power limit and within the available range of RPM. Typically lowering compressor speed, lowers power consumption and will avoid fault within the RPM range available..

The trade off with power protection intervention is that it lowers cooling capacity and increases low side pressure. The objective of power protection is to extend operation rather than encountering a component fault / cutout stopping the cooling. Once there is no more RPM turn down, fault mode is inevitable.

The graph below provides a snapshot of standard operation vs power protection looking at RPM and power consumption.

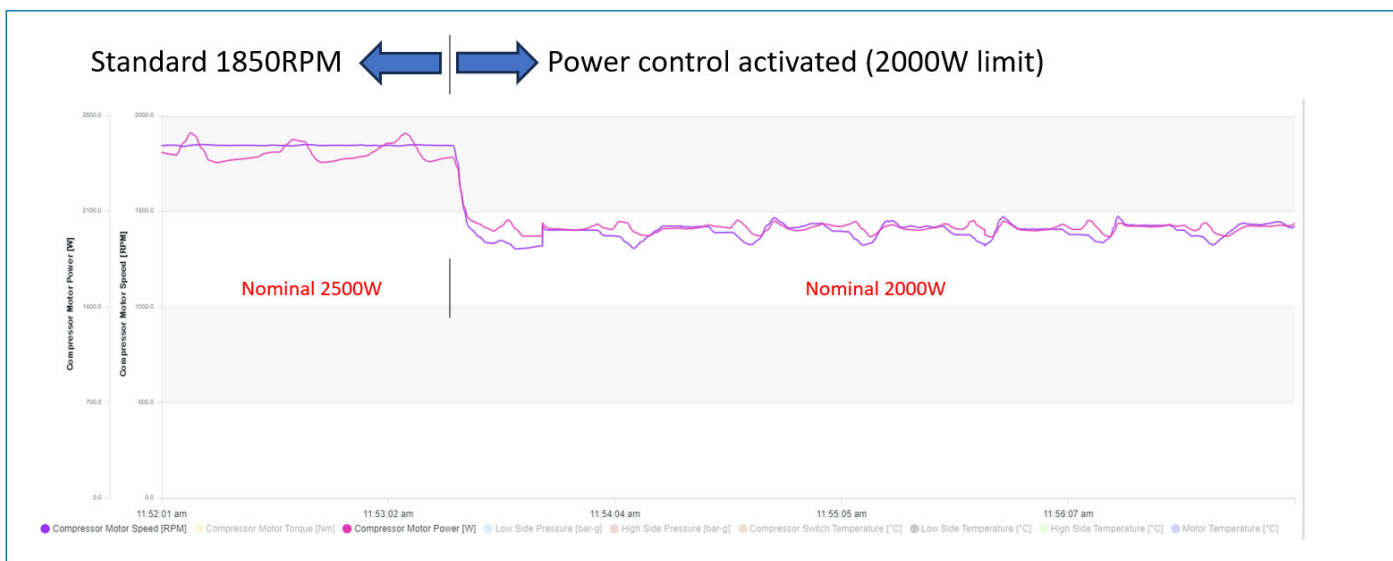

The power commissioning tab includes factory settings that will suit most applications however the commissioner can make change as required to suit the specific installation.

- **Enable:** Activate power protection.
- **Absolute limit:** Cut out
- **Correction band:** defines range of intervention.
- **Running limit:** Control point
- **Start up speed:** enables a 'soft start' which can be useful for general operation.
- **Start up speed RPM:** sets the start up RPM value .
- **Start up speed time:** defines the 'soft start' duration.

Adaptive Control - Power				Refresh	Apply
Enable	<input checked="" type="checkbox"/>		Advanced	<input type="checkbox"/>	NO
Absolute Limit	3000	W	Range: 1000 to 4500		
Running Limit	1800	W	Range: 1000 to 3000		
Running Time Limit	10	S	Range: 1 to 60		
Correction Band (%)	12	%	Range: 10 to 30		
Startup Speed Limiting	<input checked="" type="checkbox"/>				
Startup Speed	800	RPM	Range: 800 to 1850		
Startup Time	30	S	Range: 5 to 300		

The advanced tab can be enabled which opens a far wider set of parameters to change discharge pressure protection behavior. We recommend the simple interface for most users. The advanced tab is only useful for smoothing control outcomes if required.

12.5 Adaptive control – Suction control

In some applications the commissioner may want to maintain a constant suction pressure based on a set point. Unicla eDrive offers an embedded control that maintains a suction pressure within the RPM range available.

The suction pressure commissioning tab includes factory that will suit most applications however the commissioner can make change as required to suit their installation.

- **Enable:** Activate discharge protection.
- **Mode:** Control vs Protection
- **Suction pressure target:** suction pressure control set point
- **Correction band:** defines range of intervention.
- **Start up speed:** enables a 'soft start' which can be useful for general operation.
- **Start up speed time:** defines the 'soft start' duration.

Note: Suction pressure control is only available in fixed operation because we cannot have a speed control signal from the thermostat as well as managing suction pressure.

Adaptive Control - Suction Pressure		Refresh	Apply
Enable	<input checked="" type="checkbox"/> YES	Advanced	<input type="checkbox"/> NO
Mode	Control	Suction Pressure Control is only available in Fixed Speed Mode	
Suction Pressure Target	2.3 bar-g	Range: 0.5 to 3.0	
Correction Band (%)	18 %	Range: 10 to 50	
Startup Speed Limiting	<input checked="" type="checkbox"/> YES		
Startup Speed	800 RPM	Range: 800 to 1850	
Startup Time	30 S	Range: 5 to 300	

The advanced tab can be enabled which opens a far wider set of parameters to change discharge pressure protection behavior. We recommend the simple interface for most users. The advanced tab is only useful for smoothing control outcomes if required.

13. Fault output

A fault output can be incorporated using the cut end control cable. The fault output is an open drain output. This means it is floating when not asserted (i.e. no fault) and 0V when asserted. Externally, on the user end, this line needs to be pulled up via a resistor to an available supply rail to get the "high" output when not asserted.

See the diagram below. V_{dd} can be a maximum of 60V dc and value of R1 must be calculated to allow a current of 10-20mA. Resistor of appropriate power rating shall be used.

The cut end control cable, pin 3 is a motor fault signal. This line is controlled by eDrive and is asserted in the following states:

1. Not Ready
2. Fault Compressor Safety
3. Fault Motor
4. Fault FMC
5. Fault Electrical
6. Configuration fault
7. XC comms fault
8. Motor Locked
9. Motor Thermal Inhibit

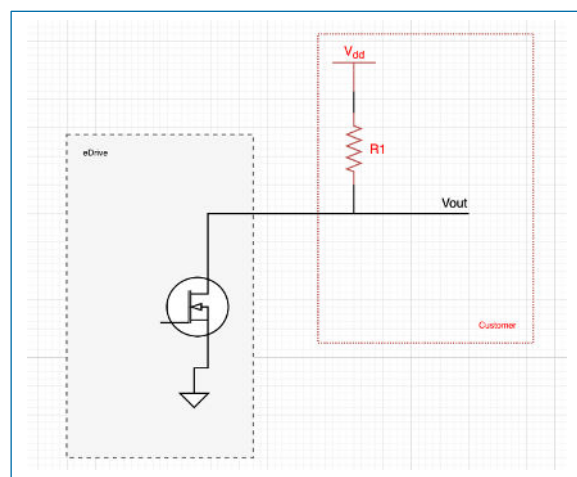

14. Other communication

14.1 Online via eConnect online <https://econnect.unicla.hk/>

If eDrive is internet connected you can view the compressor fleet online via eConnect online which presents as a similar user interface to the eConnect app. This requires a factory set up when ordering and a unique password to be supplied by Unicla.

14.2 eDrive CAN and RS485

The Unicla eDrive range of compressors have a several communication options. At the basic connection end of the spectrum are USB / ethernet which require minimal expertise for connection and management. On the other end of the spectrum is RS485 and CAN that require significantly higher skill, involvement and development from the integrator, usually for an OEM application.

Unicla provides a validated solution and technical documentation for CAN and RS485 however does not provide technical support for serial communication set up and implementation. Please ensure you have appropriate resources available to facilitate serial communication set up.

Unicla supplies a CAN / RS485 connection cable (part no. Part No. 50402-001130) as an optional accessory. This enables direct connection to the eDrive M12 CAN port and the clients CAN / RS485 circuit. Serial communications are accessed via the CAN / RS485 port.

The PCBA includes a built-in termination resistor on the CAN circuit, so externally mounted resistors are not required.

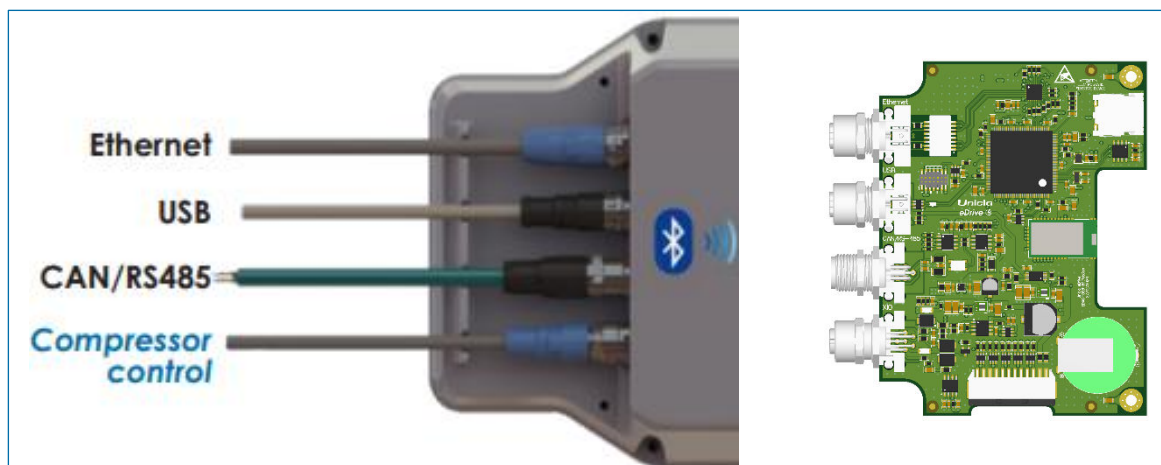

The Unicla eConnect app includes a configuration menu 'External Serial Configuration' to provide serial communication set up.

External Serial Configuration		Refresh	Apply
Mode:	RS485		
RS485 Configuration			
Protocol:	Unicla		
Address:	0x01		
Baudrate:	9600		
Enable RS485 Control:	Off		

Additional resources

[T2316-1_Unicla_eDrive_CANoverview_0424\(L\)](#)

[T2405-1_Unicla_eDrive_RS485_Interface_0325\(L\)](#)

15. Compressor status messages for eDrive

eDrive will output status messages via the eConnect dashboard and CAN communication channels. Below is a list of status reporting and meanings.

0 = Not ready

eDrive is going through boot up process. This would normally be seen only after power on. Should this message continue longer than a few minutes, contact Unicla support.

1 = Starting

eDrive has two basic operational states. The starting phase is the initial operational state and has its own set of non-user configurable limits to promote start reliably and compressor safety. The starting phase will end after a factory set time then transition to running phase.

2 = Running

The running phase is the normal run operation. Running phase is constrained by both user limits available in the commissioning and other non-user accessible limits. Should this limit threshold be breached, the compressor will stop and display a fault message indicating the reason for stopping.

3 = Stopped

When the compressor has resolved any faults and completed any anti-short cycle timing it will be in stopped status. This indicates the compressor is ready to start when called.

4 = Wait compressor safety

When fault has been triggered, the system will wait until the parameter is within limits before transitioning to stopped.

5 = Wait anti-short

eDrive incorporates an anti-short cycle timer that prevents operation. The anti-short becomes active after a stop event and once the timer completes the compressor will return to the stopped status. The anti-short timing can be changed in commissioning.

6 = Fault compressor safety

eDrive has factory set limits for the physical aspects of the system that if breached cause a fault. Observe the fault description and rectify if necessary. Power cycle compressor and retest.

7 = Fault motor

eDrive has factory-set limits for the motor and internal components that if breached cause a fault. Observe the fault description and rectify if necessary. Power cycle compressor and retest. Contact Unicla support if message continues.

8 = Fault FMC

Contact Unicla support

9 = Fault electrical

Validate supply voltage is correct and power cycle. Contact Unicla support if message continues.

10 = Fault configuration

Contact Unicla support

11 = Fault XC comms

Contact Unicla support

12 = Locked

In most cases a fault will reset once the fault condition is self-rectified. When the compressor has faulted five times for the same fault it will enter the locked status which prevents further operation until investigation and intervention. To remove the locked status use eConnect and press *Stop* or power cycle the compressor.

13 = Motor thermal inhibit

eDrive has factory set temperature limits for the motor and internal components. This inhibit will prevent compressor start to allow compressor cooling before restart.

14 = Oil balance running

(refer section 11e for oil balance detail)
Oil balance function in progress

15 = Oil balance required

(refer section 11e for oil balance detail)
If an oil balance function failed due to a loss of control demand, power off or other factors it will set an oil balance required status. This indicates that an oil balance will occur next start.

16 = Oil balance run wait

(refer section 11e for oil balance detail)
Oil balance will start on next call to run.

16. Starting the system

Once all piping and pre-charging is complete and the system is energised, the compressor will be by default in the eConnect control mode and stopped. Go to the commissioning page and set the desired mode of operation and press *Apply*.

Turn on the thermostat, at which point you should see either the remote enable indicator or the variable demand or both in the dashboard. The status should be stopped and will then initially carry out an oil balance start (OBS) and transition to run.

This check list traces the important steps that will ensure the eDrive compressor is installed and operating within Unicla recommended guidelines.

Use this check list to complete the eDrive compressor operation analysis form that is supplied with each compressor.

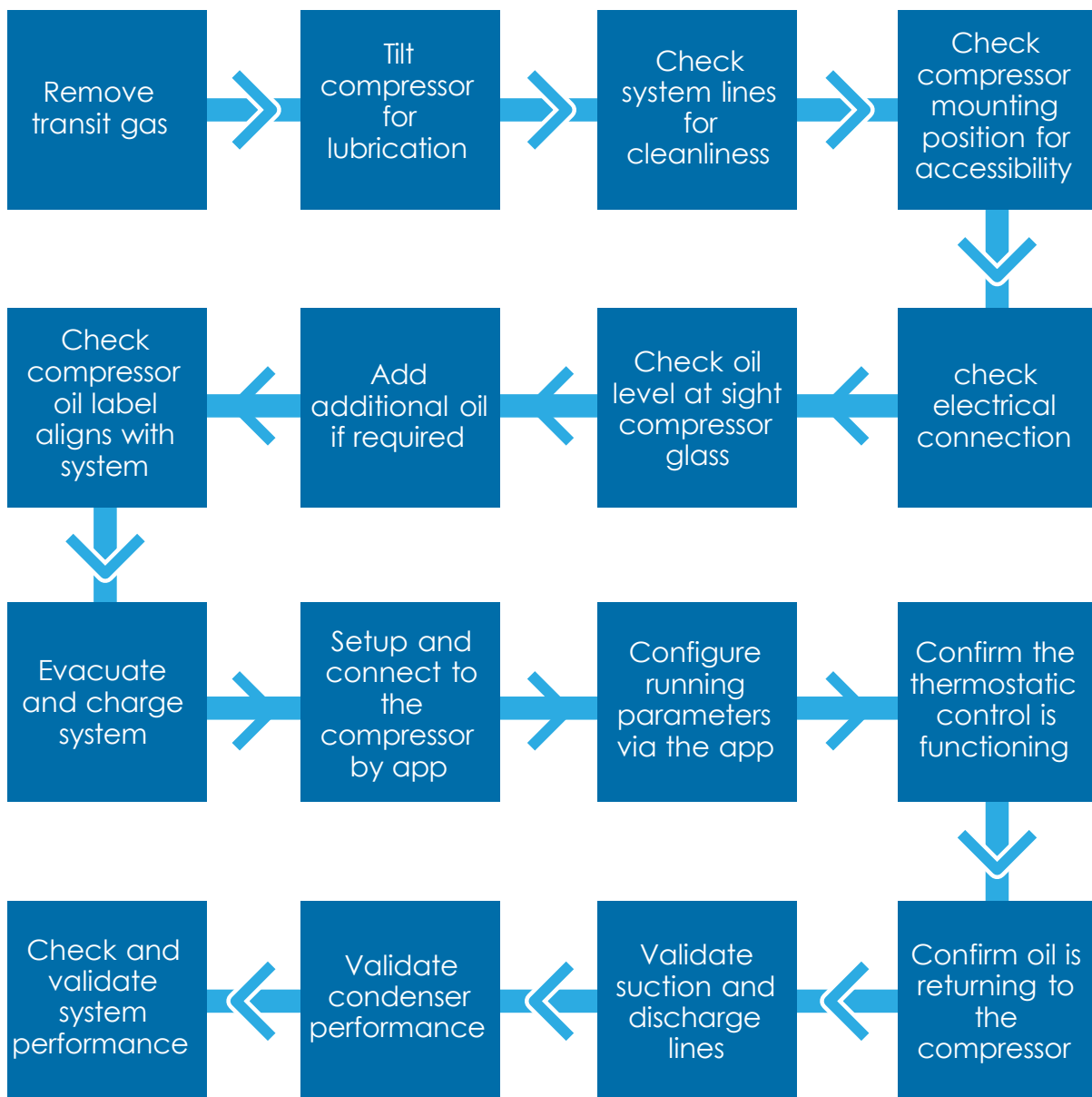

Commissioning check list

17. Troubleshooting guide

Compressor won't connect via eConnect

- Confirm that the selected protocol connection cable is fitted.
- Confirm that the compressor is powered by the correct Vdc and if so, power cycle and re-try connection.
- If using an ethernet cable, try a USB cable.

Compressor won't start

- Confirm that the selected protocol connection cable is fitted.
- Confirm that the compressor is powered by the correct Vdc.
- Connect via the eConnect app.
- Check how the compressor is configured – fixed speed/variable speed? Does a remote enable signal show on the dash? Carry out checks to confirm a thermostat output.
- Simulate a start signal.
- If variable speed, has a remote enable function been requested? Is this active?
- Does the compressor start manually via eConnect control?
- Confirm if there are active alarms or errors and resolve them if required.
- What is the start delay time nominated? This will impact start times.

Compressor isn't operating as expected

- Review the selected commissioning options in eConnect.
- Confirm the thermostat signal is outputting correctly.
- If the compressor protection is activated, it will intervene by either managing compressor speed or stop the compressor rotation.
- Confirm if there are active alarms or errors and resolve them if required.

Compressor motor overheating

- Inspect the installation to ensure it meets the ventilation and physical characteristics required.
- Inspect the fan intake for dust and obstruction and check for evidence of significant dust build up. Refer to the service manual to remove the enclosure and fan assembly.
- Ensure that the cooling fins on the motor casing, the fan and intake grill are cleaned of dust obstruction.
- Check the fan operation when the compressor is rotating. Is there air movement at the fan inlet?
- Is there any noise of fan rotation?

18. General internal layout

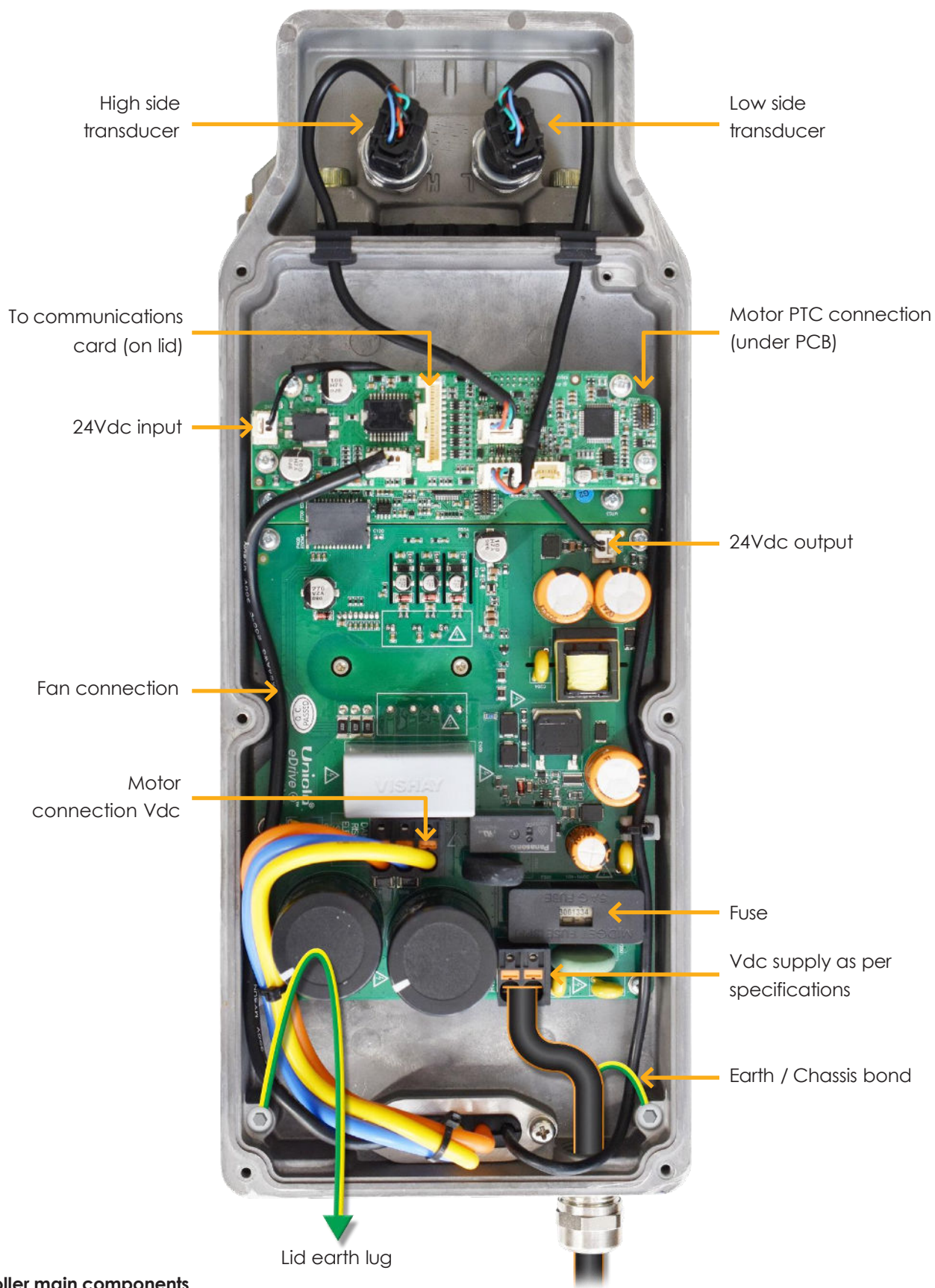

Controller main components

19. Operational checks and maintenance

The Unicla compressor's high efficiency and durability will provide many years of service. To maintain the compressor, the following checks should be carried out periodically to ensure its high performance.

All physical checks should be carried out when the system is powered down and electrically isolated where appropriate. Always use a multimeter to confirm residual voltage has been dissipated before working on the unit.

Operational check list

- Log on to eConnect and confirm the system is performing as expected and check for any errors in the history logs.
- Check the tension on all bolts and fasteners such as mounts, motor/compressor, lid, and glands.
- Inspect the cooling fan air inlet and outlet for dust and dirt buildup. If the dust coverage is light and not restricting flow at the inlet grill, use a compressed air gun to remove surface dust. If there is evidence of significant dust buildup, remove the fan cover (refer the service manual) and clean out the fan cover, fan impeller and air ducts with a combination of compressed air, mechanical cleaning by hand, soft bristle brush and or pipe cleaner. Compressors operating in particularly dirty or dusty environments should be inspected more frequently.
- The external surfaces (not electrical/PCB areas) may be wiped with a cloth or cleaned with compressed air. Do not use a hose or flowing water to clean any part of the compressor.
- Check the tension on all compressor mounts, electrical terminations, glands and cables.
- Inspect the electrical Vdc supply cable for rubbing or wear. Inspect the electrical enclosure interior and PCBs for dust or moisture ingress.
- Check refrigerant hoses, connections and system for leakages. Check all heat exchangers for correct fan operation and coil blockage.
- Check level and condition of the compressor oil. Refer to section 18.

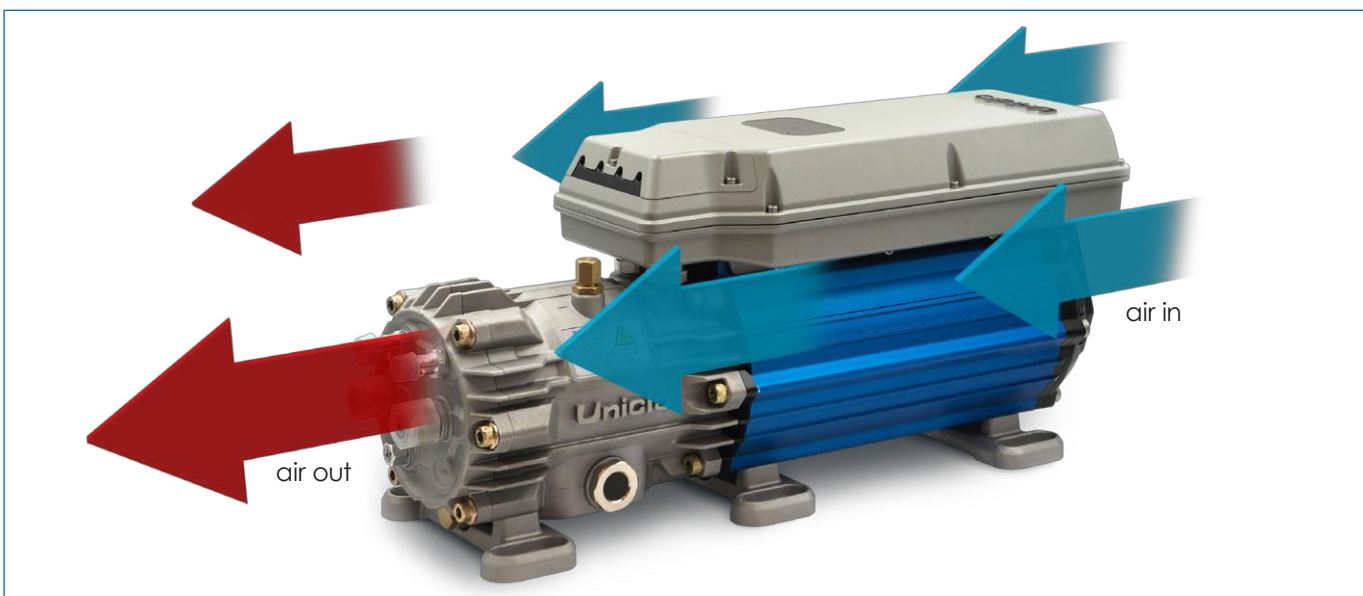

Motor cooling fan and jacket design

20. Installation, control and electrical notes

- **eDrive is not intended to be stopped while running by cutting power to the compressor.** Cutting power to stop is only an emergency stop option and not considered a repetitive control method.
- eDrive must be powered by its own circuit to the power supply. Multiple loads such as fans and heaters on the same circuit are not acceptable. Consult Unicla for further advice if required.
- In all installations, the power supply circuit must be investigated and validated to ensure there is sufficient stable capacity available to operate eDrive and any ancillaries that maybe using the same supply. (refer the Unicla eDrive specification). Should the power supply be deficient, voltage drop, and potential compressor cut out and or damage is possible.
- Voltage spikes in the voltage supply circuit are not desirable and potential compressor damage is possible. Voltage supply must remain within the specified range.
- Ensure that the cable sizing is appropriate for the power rating. Should the cable size be deficient, voltage drop, and potential compressor damage is possible.
- All interconnections must be well terminated to ensure that no electrical limitations or shorts exist otherwise potential compressor damage is possible.
- Voltage polarity needs to be confirmed as correct before energizing the compressor. Potential damage to the compressor is possible should polarity be reversed.
- It is recommended that power isolation and circuit protection be incorporated in accordance with local regulation.
- All electrical work must be carried out by competent qualified personnel in accordance with local regulation.
- High levels of electromagnetic interference can affect operation of communications cabling and internal components in eDrive. Consult Unicla for further advice should you suspect these conditions exist in your application.
- eDrive is primarily intended for operation with air to refrigerant heat exchanger systems operating in air conditioning and refrigeration duty . Consult Unicla for further advice for alternate applications.
- For fixed installations or where a functional earth exists, an earth connection is required via the eDrive fly lead. Consult AS3000 or relevant standard for guidance.
- For mobile applications where no functional earth exists such as a rubber tire vehicle, there are 2 approaches to the 'earth / chassis bond' wire. Often eDrive is hard mounted to the vehicle chassis directly. In this case the fly lead earth / chassis bond wire may not be required. In cases where there is a non-conductive layer between eDrive and chassis such as when using anti-vibration feet, then the earth / chassis bond should be used for bonding the eDrive casing to the chassis. As always, underpin all electrical installation with adherence to AS3000 and/or relevant standards

21. Compressor sight glass visualisation and diagnosis

The following charts will be useful for checking the sight glass of the compressor after commissioning the system. Different operating conditions will present variable symptoms to appear at the sight glass and Unicla recommends this must be checked both immediately after commissioning and at future regular intervals during service.

To obtain the best possible visual of the sight glass, it is recommended the rear sight glass is back lit with a good quality white light, preferably from an LED torch or headlight. This will produce good light through the center of the compressor sump to allow accurate evaluation of the oil level and quality.

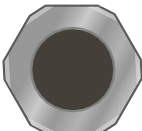
Visual	Sight glass	Oil	Operation	Recommendation
	Normal > high point	Normal – clear and transparent	OK	Nil
	Normal > high point	Possible slight moisture contamination, or high temperature operation	OK	Monitor oil condition and change if necessary
	Normal > high point	Green slime – copper hydroxide present	OK	Monitor oil condition and change if necessary
	Oil level low < half point	Normal – clean and transparent, dark section is oil foam not contamination	Oil flow or level is low	Check suction pressure and system oil quantity
	Oil level low < half point	Normal – clean and slight orange or red colour	Oil flow or level is low and running at high temperature	Check suction pressure and system oil quantity
	Oil level < low point	Not visible	Oil flow or level is critically low - damage to compressor will occur Suction pressure is most likely at 1.0 bar (14 psi) or less and must be rectified	Cease system operation and check suction pressure and system oil quantity
	Normal > high point	Black and cloudy – severely contaminated	Compressor will fail	Cease system operation - clean and flush system, replace compressor oil
	Oil level < high point	Dark black – severely contaminated and has black sludge	Compressor will fail	Cease system operation - clean and flush system, replace compressor oil

Compressor sight glass visual checks

eDrive compressor operation analysis

Installation details	
Owner name	
Contact details	
Phone	
Contractor	
Electrician	
Vehicle type	
AC system type	

Compressor details			
Compressor model		Date purchased	
Serial No.		Invoice No.	
		Date installed	

System information				
Refrigerant / quality	/	kg	UV dye added	yes / no
Input voltage			Oil separator fitted	yes / no
Oil type / quantity	/	kg	Accumulator fitted	yes / no

eConnect commissioning settings			
Variable / fixed speed		Anti short cycle time	
Control signal	4 - 20 ma / 0 - 10 Volt	Ramp speed - rate of change	
Remote enabled	yes / no		

Operation analysis at MAXIMUM speed setting in eConnect				Operation analysis at MINIMUM speed setting in eConnect			
Discharge pressure		Suction pressure		Discharge pressure		Suction pressure	
Discharge temp		Suction temp		Discharge temp		Suction temp	
Discharge superheat		Suction superheat		Discharge superheat		Suction superheat	
Check oil level	<input type="checkbox"/>	Check refrigerant SG	<input type="checkbox"/>	Check oil level	<input type="checkbox"/>	Check refrigerant SG	<input type="checkbox"/>

Other information	

Unicla®

Unicla International Limited
Hong Kong: +852 2422 0180
Australia: +61 7 5549 4000

www.unicla.hk
sales@unicla.hk

