

Unicla®

eDrive™



UD150 | UD200 Service manual

48 and 72 Vdc series

Unicla®

An exploded view diagram of a Unicla motor assembly. The diagram shows various components including a top housing, a motor core with windings, a bottom housing, a fan, and various screws and bolts. The components are arranged in a way that shows their relative positions and how they fit together. The Unicla logo is visible on the motor core.

Copyright © 2020 All rights reserved

No part of this document shall be reproduced in whole or in part without the permission of Unicla International Limited. This includes reproduction or copies in any form or by any means including photocopying, printing or electronic media.

IMPORTANT DISCLAIMER

This is a guideline document containing professional information using representative graphs, charts and tables. Manufacturers' specifications must be consulted for specific guidelines and performance data. Unicla published data, specific to all models, is available in promotional literature and from Unicla International Limited on request or through your Unicla supplier.

Unicla International Limited expressly disclaims all and any liability and responsibility to any person or business as a result of any actions taken on the basis of information in this publication.

Table of contents

1. Specifications.....	1
2. Component part list.....	3
3. Service tools.....	5
4. Assembly and disassembly procedure.....	6
4.1 Motor removal from compressor.....	6
4.2 Compressor.....	7
4.2.1 Lip seal.....	7
4.2.2 Rear cap.....	8
4.2.3 Mount.....	10
4.2.4 Oil.....	10
4.3 Remove fan assembly.....	11
4.4 Remove transducers.....	13
4.5 Mount.....	13
5. System oil.....	14
5.1 Quantity.....	14
5.2 Oil type and grade.....	14
5.3 Storage guidelines.....	14

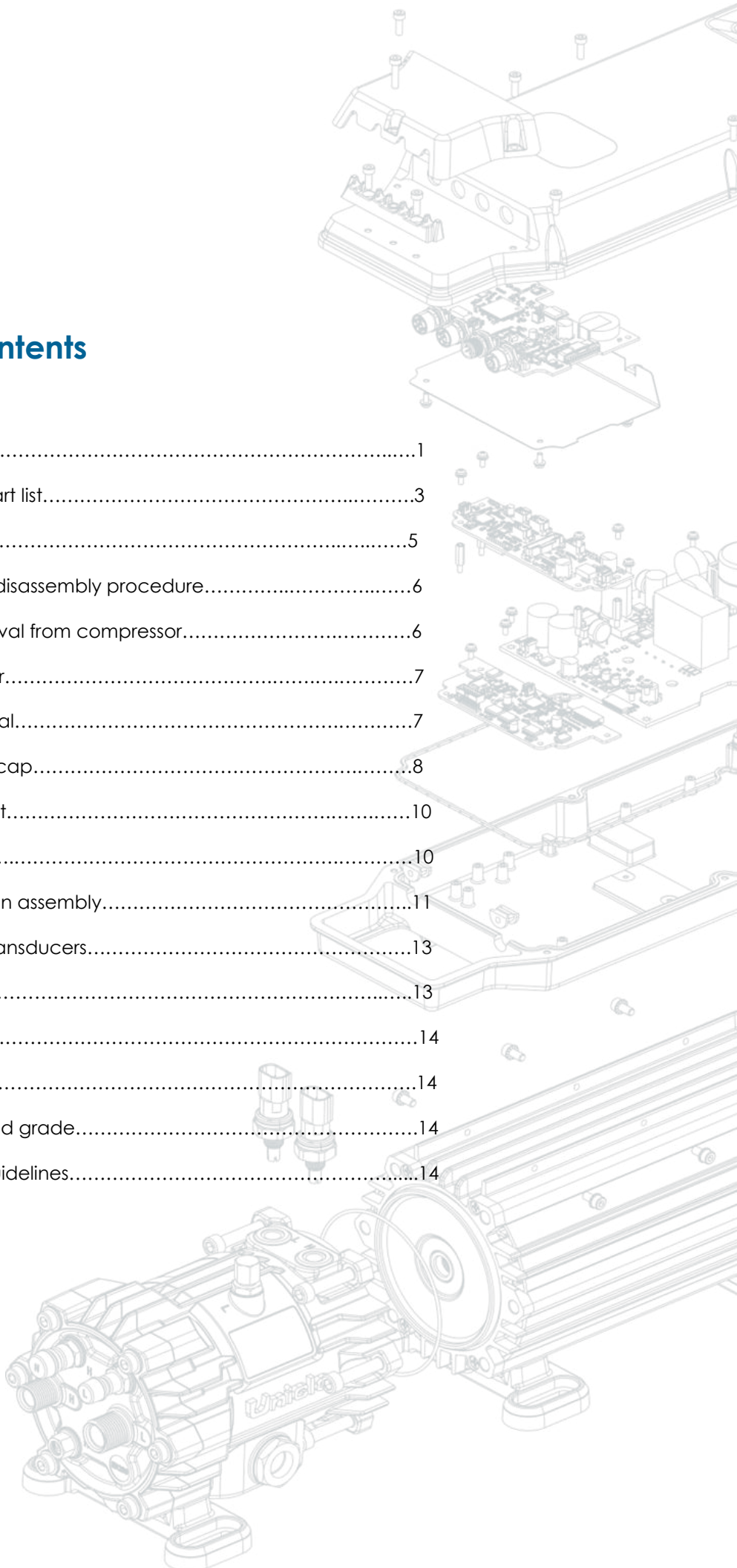

1. Specifications

Model	UD150
Number of cylinders	10
Displacement	145cc/rev
Refrigerant	R134a – R513a – R1234yf
Initial oil change	200cc
Oil type*	Depends on the refrigerant type
Weight	25kg
Motor	48 or 72 V dc

*Refer to section 5 (System oil) for more details of the oil type

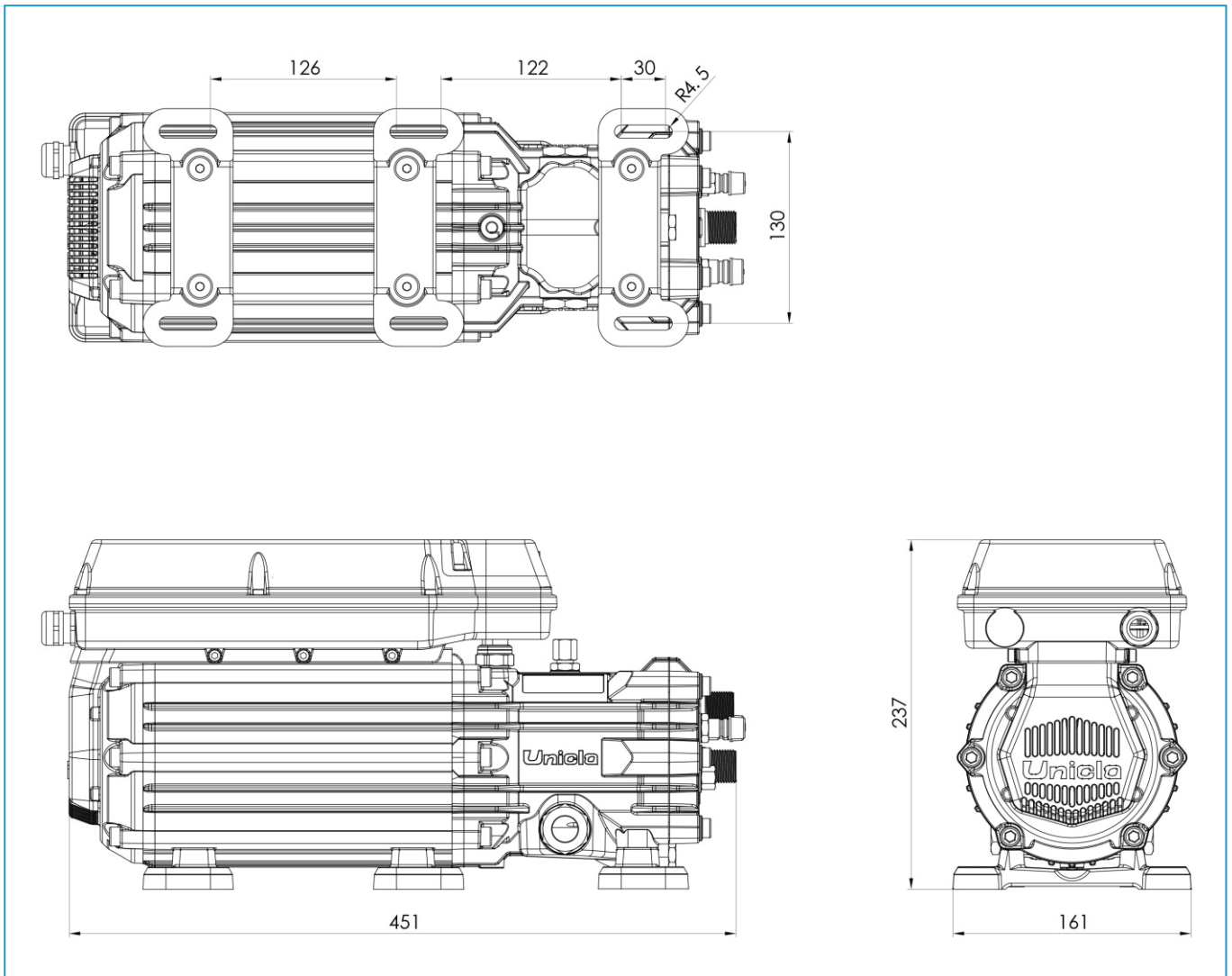

1. Specifications

Model	UD200
Number of cylinders	10
Displacement	200.4cc/rev
Refrigerant	R134a – R513a – R1234yf
Initial oil change	250cc
Oil type*	Depends on the refrigerant type
Weight	26kg
Motor	48 or 72 V dc

*Refer to section 5 (System oil) for more details of the oil type

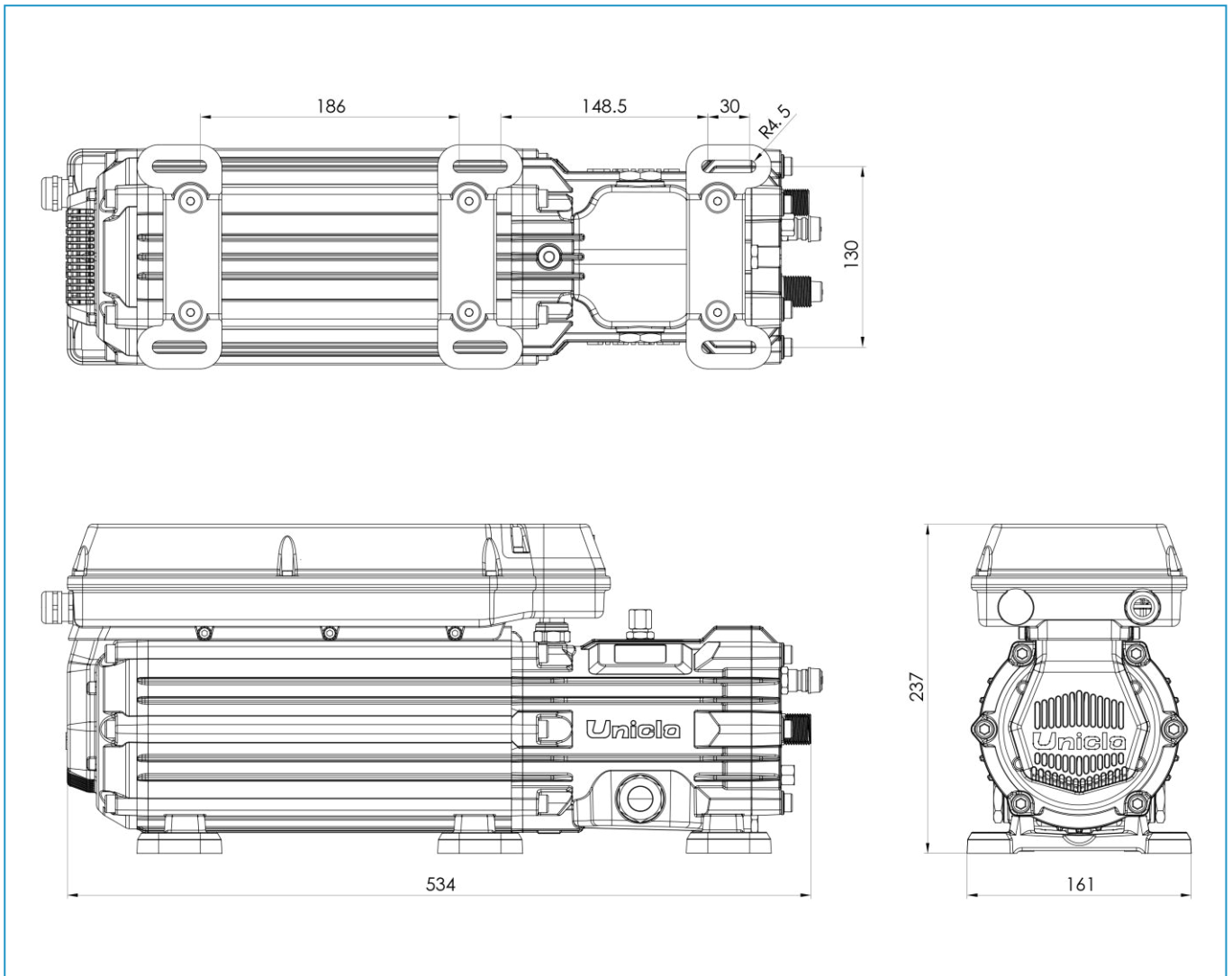

2. Exploded view

Part numbers next page

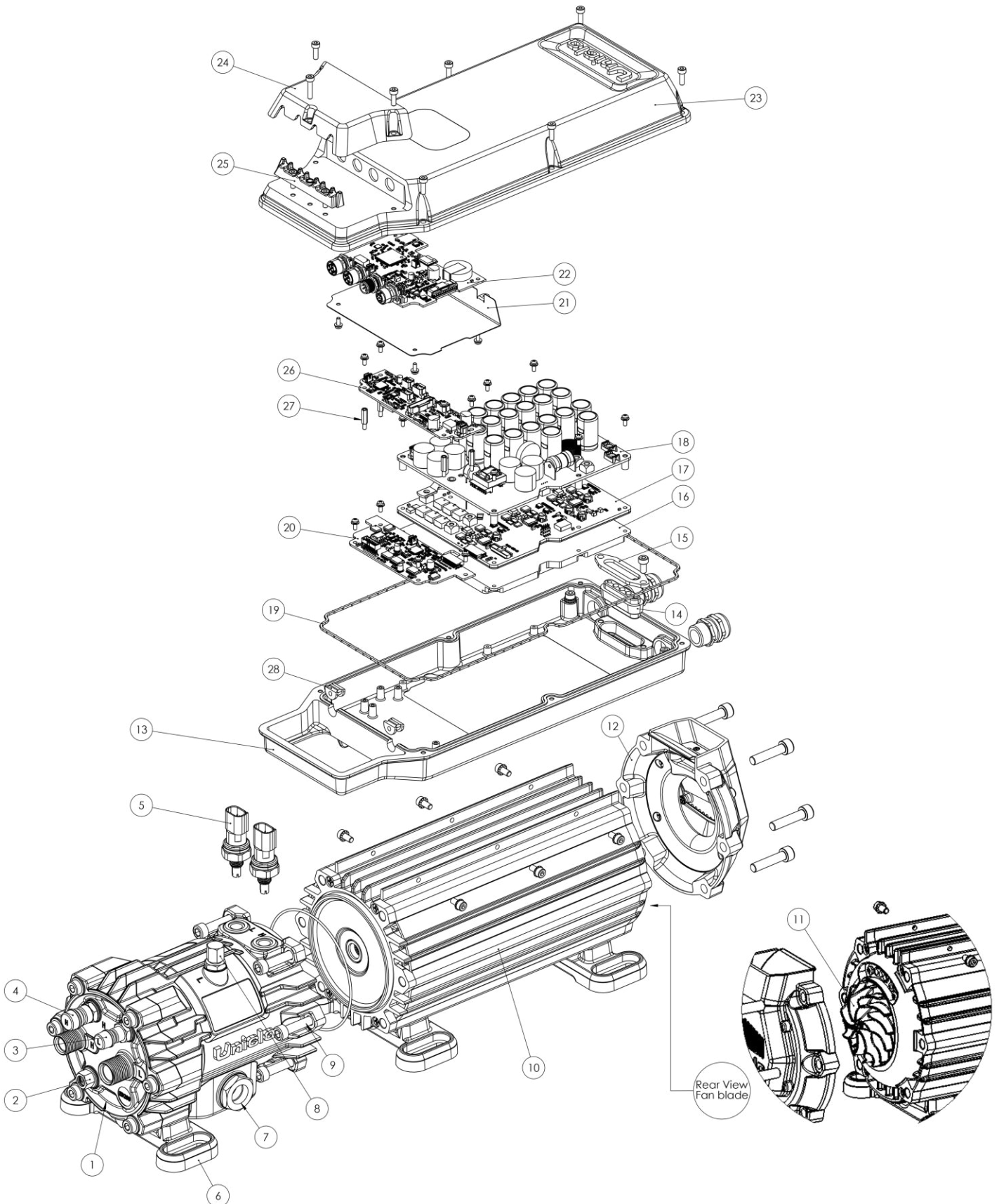

2. Part numbers

Item No.	Description	Part number
1	Rear cap	21504-000230
2	Relief valve	38305-000030
3	Low side service valve	38101-000020
4	High side service valve	38101-000030
5	Transducer	53101-000190
6	Mounting foot	32308-001120
7	Sight glass	35801-000010
8	Oil return port	42203-000161
9	Dust O-ring	92701-000010
10	Motor assembly UD150-48 V dc	60100-00075
	Motor assembly UD150-72 V dc	60100-00025
	Motor assembly UD200-72 V dc	60100-00035
11	Fan motor	Part of motor
12	Fan motor housing	60030-00005
13	Controller housing UD150 48-72 V dc	60040-00025
	Controller housing UD150 400-600 V dc	60040-00005
	Controller housing UD200 72 V dc	60040-00025
	Controller housing UD200 400-600 V dc	60040-00015
14	Motor cable gland	62020-000100
15	Motor cable retainer	62020-000090
16	UDPC power card heat spreader	64040-000040
17	UDPC power card 48 V	62020-000330
	UDPC power card 72 V	62020-000330
18	UDPC mezzanine power card 48 V	62020-000320
	UDPC mezzanine power card 72 V	62020-000310
19	Enclosure gasket	92601-000010
20	UDCMC compressor card	62020-000080
21	UDXC shield	62020-000180
22	UDXC communication card	62020-000050
23	Enclosure lid	Part of housing
24	Connections cover	62020-000020
25	Cable support	62020-000140
26	UDFMC fan control card	62020-000060
27	PCB stand	62020-000110
28	Transducer gland	62020-000160
Accessories		
1	USB communication cable	50402-001100
2	Ethernet communication cable	50402-001120
3	Control cable with 4P Deutsch plug	50402-001190
4	Control cable no plug	50402-001080
5	CAN communication cable	50402-001130

3. Service tools



Circlip pliers
Generic



Guide sleeve
Part 03301-000330



Shaft rotating handle
Part 03301-000340



Installer – ring and seal
Part 03301-000320



Seal remover
Part 03301-001000



Torque wrench
Generic

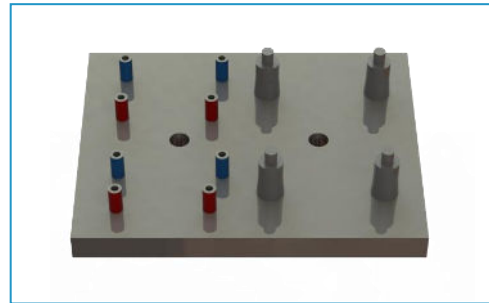

Assembly stand



Flat screwdriver
Generic



Phillips screwdriver
Generic



Allen key
Generic



Socket wrench set
Generic



Adjustable wrench
Generic



Safety equipment

Always carry out a risk assessment before starting any work on the system or compressor

Always use appropriate protective equipment where required such as safety glasses, gloves and safety boots

4. Assembly and disassembly procedure

4.1 Removal of the compressor from the motor

a) Remove the electrical enclosure lid

Tools required: Allen key

Procedure:

Confirm the power supply is isolated.
Remove the six screws and gently lift the lid up by approximately 100mm.
Disconnect the interconnecting cable and earth lug between the base and the lid.
Remove the lid assembly.

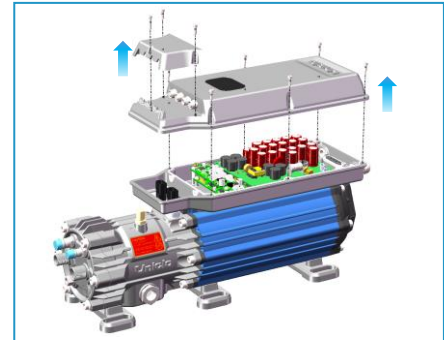

b) Loosen the interconnecting cables

Tools required: Allen key

Procedure:

Remove the two screws from the cable gland retainer near the fan end of the base. Slide the retainer over the cable assembly free of the gland hole and remove the gland halves from the base. The cables now have free movement of the enclosure.

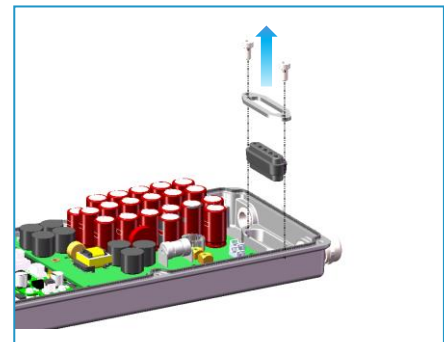

c) Loosen the controller housing

Tools required: Allen key

Procedure:

Remove the transducer plugs from the top of the transducers. Remove the six screws retaining the enclosure base to the motor and slowly lift the enclosure base upward while feeding the cables through the hole in the enclosure base. (It needs to be raised only 20 to 30mm). Lay the base back onto the motor.

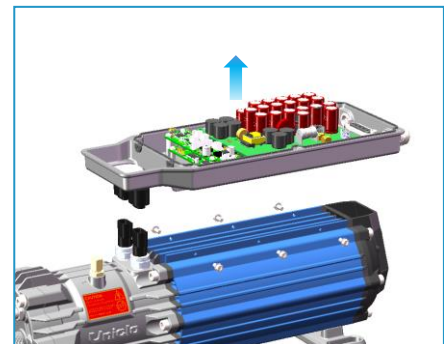

d) Remove the compressor from the motor

Tools required: Allen key

Procedure:

Remove the six bolts retaining the compressor to the motor. Gently raise the enclosure base at the transducer end so that the base is above the height of the transducers. While the base is elevated, support the underside of the compressor with one hand and gently pull it away from the motor.

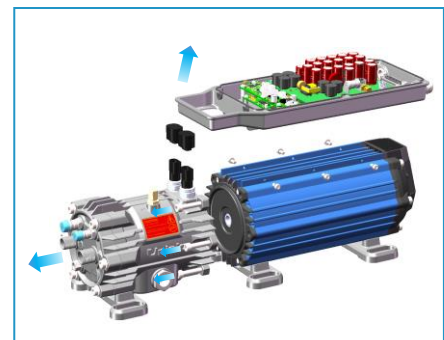

Assembly is the reverse procedure.

4.2 Compressor assembly/disassembly procedure

4.2.1 Lip seal

a) Remove snap ring

Tools required: Snap ring pliers (hole)

Procedure: Remove the snap ring slowly with pliers.



b) Remove lip seal

Tools required: Lip seal remover

Procedure: Insert the lip seal into the recess, turn around lightly and pull out.

Note: Inspect the condition of lip seal and snap ring to ensure they are both in one piece and not deformed.



c) Setting the guide sleeve

Tools required: Stand guide sleeve

Procedure: Place compressor on the stand. Lubricate outside of the guide sleeve and insert into the shaft of the compressor.

Caution - the sleeve must be clean and unmarked.



d) Installation of the lip seal

Tools required: Guide sleeve lip seal installer

Procedure: Slip the lip seal over the guide sleeve by hand. Place the installer on the lip seal correctly.

Press the lip seal with the remover until it stops. Then remove the guide sleeve.



4.2 Compressor assembly/disassembly procedure

4.2.1 Lip seal

e) Assembly of the snap ring

Tools required: Snap ring pliers (hole) installer ring

Procedure: Insert the snap ring into nose section (tapered part of the snap ring must be facing downwards).

Push the snap ring downward with the installer ring and fit into groove.

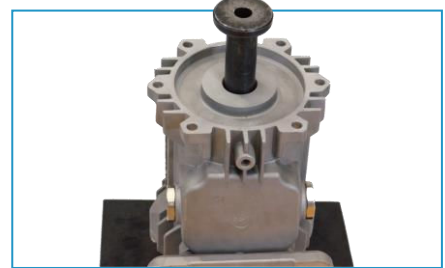
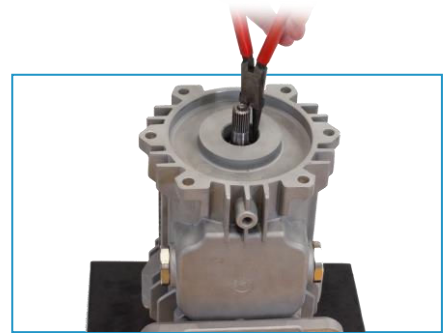

4.2.2 Rear cap

a) Remove oil

Tools required: 17mm socket, wrench and shaft rotating handle

Procedure: Remove the drain plug and drain the oil. Use the shaft rotating handle to assist with evacuating oil by rotating the working assembly (if required).

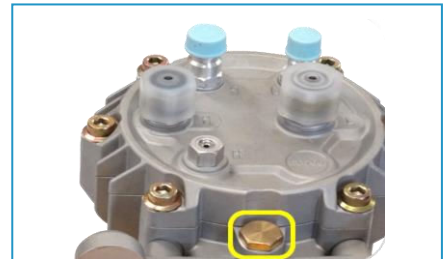

b) Remove bolts on rear cap

Tools required: 6mm AF In-hex socket, wrench and assembly stand

Procedure: Remove the securing cap bolts (5pcs) from the rear cap.



c) Remove the rear cap

Tools required: Screwdriver (flat) or suitable lever and assembly stand

Procedure: Remove the rear cap by gently inserting a screwdriver or lever into the recess. Lever all around, not just at one position.

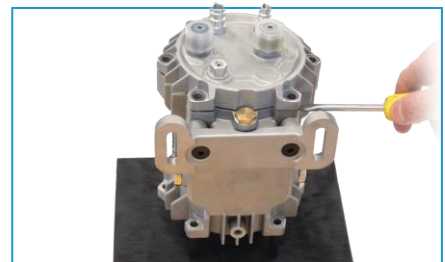

Caution - Do not damage the end of front cap and body.

d) Working assembly

Inspection: Once the rear cap is removed the working assembly is exposed including the valve plate and gasket.

Caution – do not allow dirt and debris to enter the compressor casing and working assembly.

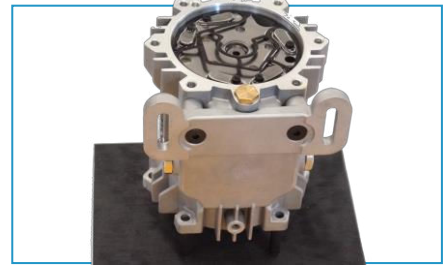

e) Installation of the rear cap O-ring

Procedure: The O-ring must be free from marks and dust. Thoroughly lubricate new O-ring properly and insert into the groove. Ensure the O-ring is lying straight in the groove without a twist.



f) Assembly of the rear cap

Tools required: Torque wrench with 6mm in-hex socket

Procedure: Place the body with front section facing upward. Place the rear cap on the body (be careful not to twist the O-ring). Tighten in-hex cap bolts (5pcs) with torque wrench to a torque setting of 34.3 ± 1 N.m. Use a proper tightening sequence to ensure a uniform pull down across the cap.

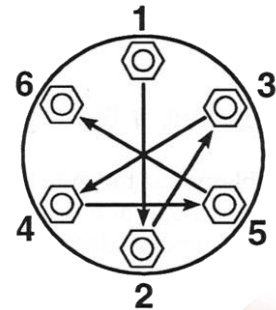
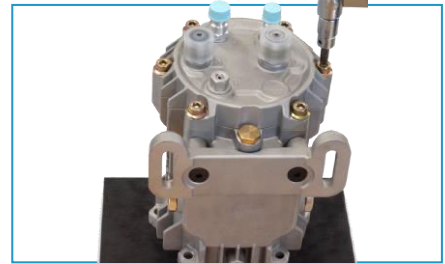

g) Test the rotation

Tools required: Shaft rotating handle

Procedure: Install the handle into the front section to check the shaft rotates smoothly.

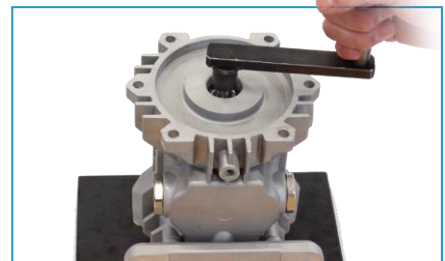

4.2.3 Mount

a) Installation of the compressor mounting

Tools required: Allen key wrench

Procedure: Align the bolt holes of the mount with the compressor. Insert hex bolts and tighten.

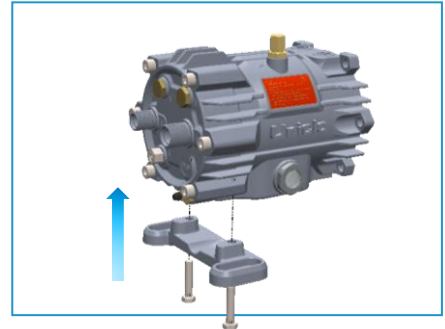

4.2.4 Oil

a) Add oil to compressor

Tools required: 17mm socket and wrench - funnel (if required) - pouring jug

Procedure: Remove the oil return port. Use a funnel or jug with pouring lip to fill the compressor via the oil return port. UD150 sump capacity is 200ml.

Standard oil type: Unidap 7 (PAG) or Unidap 6 (POE). Refit the oil return port and tighten to a torque of 24.5 ± 1 Nm. Use nitrogen at 150psi to confirm for leaks. Leave the nitrogen holding charge in the compressor until installation.

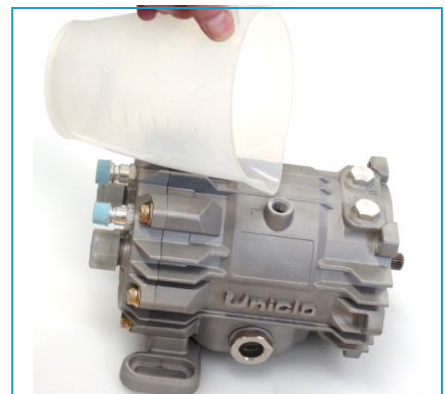
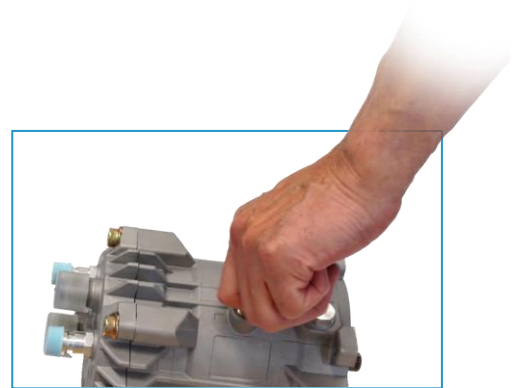

4.3 Remove fan assembly

a) Remove electrical enclosure lid

Tools required: Allen key

Procedure: Confirm the power supply is isolated. Remove the six screws and gently lift the lid up by approximately 100mm. Disconnect the interconnecting cable and earth lug bolt between the base and the lid and remove the lid assembly.

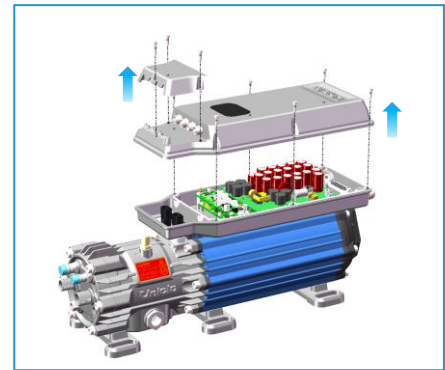

b) Remove gland and retainer

Tools required: Allen key

Procedure: Remove the two screws from the cable gland retainer near the fan end of the base. Remove the retainer and gland halves from the base.

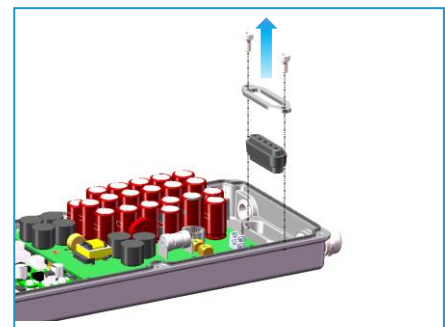

c) Interconnecting cables

Tools required: Various

Procedure: Depending on the length of cables, it may be necessary to disconnect the cables as shown. Unplug or remove wire where applicable.

Cable No.	Connection
1	Transducer cables
2	Motor 3 Phase 48-72Vdc
3	Fan motor cable
4	Motor PTC cable
5	24V interconnect

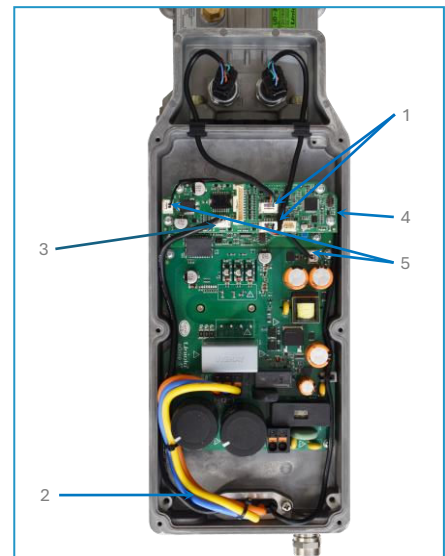

d) Loosen the controller housing

Tools required: Allen key

Procedure: Remove the transducer plugs from the top of the transducer. Remove the six screws retaining the enclosure base and slowly lift the controller and enclosure (disconnect the cables if necessary).

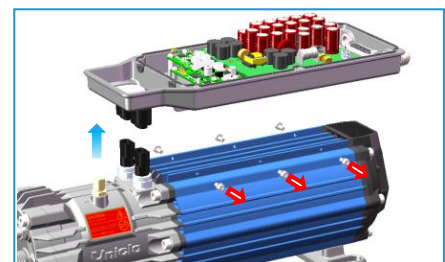

Note: Protect the PCBs from moisture, dust and static charges

e) Remove air deflector

Tools required: Phillips head screwdriver

Procedure: Remove the two screws retaining the plastic air deflector and slide it along the cables out of the way.



f) Remove fan housing assembly

Tools required: Allen key

Procedure: Remove the six bolts retaining the outer fan housing and remove the housing.

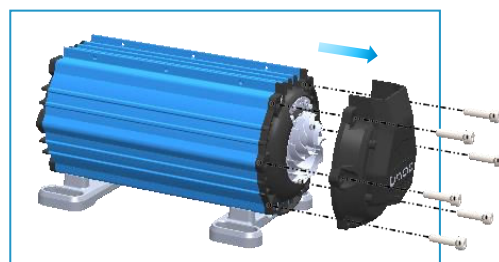

g) Remove impeller fan assembly

Tools required: Socket

Procedure: Remove the nut retaining the fan impeller onto the motor shaft and remove the fan impeller.

Note: There is a flattened shaft keyway so the impeller can go on in only one orientation.

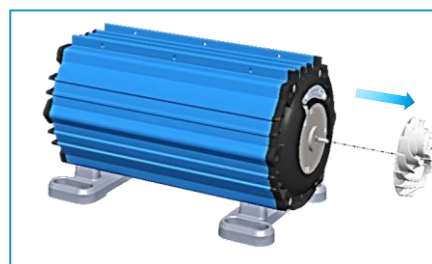

h) Remove impeller fan assembly

Tools required: Phillips screwdriver

Procedure: Remove the three screws retaining the fan motor into the casing. Gently dislodge the motor housing and plastic cable retainer before pulling the motor from the assembly.

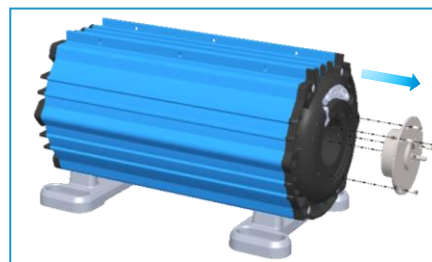

4.4 Remove transducers

a) Preparation

Procedure: Remove the electrical enclosure assembly as described previously in the fan removal section. Confirm the system is de-pressurised or carry out de-pressurisation and refrigerant recovery from the system.

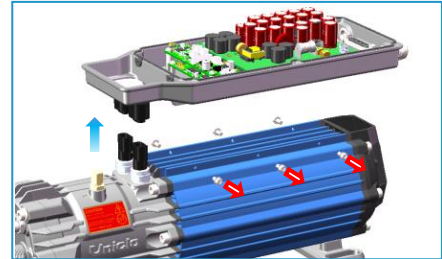

b) Remove/Install transducers

Tools required: Adjustable wrench

Procedure: Screw/unscrew the transducers with the adjustable wrench.

Note: Ensure the sealing O-ring is in place and lubricate it with compressor oil. Do not overtighten.

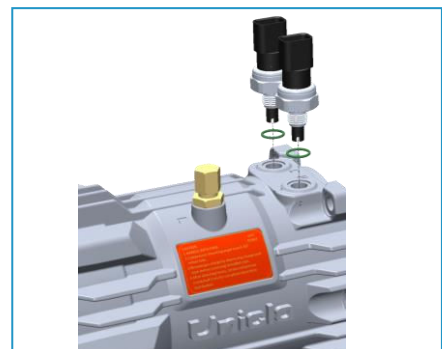

4.5 Mount

Installation of the motor mounting

Tools required: Allen key wrench

Procedure: Align the bolt holes of the mount with the motor. Insert in hex bolts and tighten.

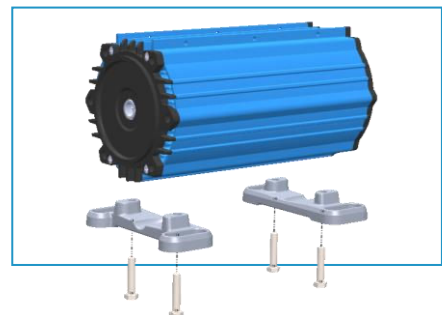

5. System oil

5.1 Quantity

The correct amount of oil must be maintained in the compressor and system. Long hose runs and dual evaporator systems must have additional oil added to the system. Severe oil starvation problems may result from insufficient system oil. To determine the required oil quantity, Unicla recommends a calculation as a percentage of refrigerant charge as follows:

20% for UD200 compressors in standard applications where the suction and discharge lines are less than six metres in length.

Example:

Calculate oil charge as 20% of refrigerant charge, 5kg charge = 5000g x 20% = 1000ml (cc) of oil. If fitting a UD200 compressor, then deduct the compressor initial oil charge to determine amount of oil to be added. Therefore 1000 – 200 = 600cc oil to be added to system.

5.2 Oil type and grade

Each eDrive compressor is factory charged with either Unidap PAG or POE oil. The compressor is fitted with a specific label that will identify the factory charged oil type in each eDrive compressor. When adding oil to the system, Unicla Unidap oil or a factory approved equivalent oil must be used.

Note: Warranty is void if non-approved oils and refrigerants are used.

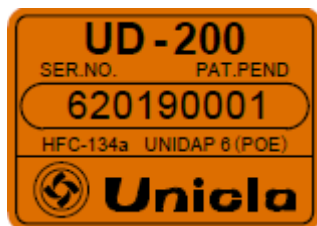
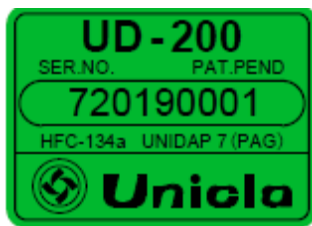

5.2 Storage guidelines

- I. Evacuate compressor for three minutes and fill with nitrogen (N₂) at 0.1 ~ 0.2MPa.
- II. Place the compressor in a clean and dry area with low humidity and tag with details.
- III. Keep compressor away from direct sunlight.
- IV. Store the compressor horizontally on a flat, even surface.
- V. Do not store the compressor in temperatures above 30°C.
- VI. Place the compressor in a well-ventilated area to avoid corrosion damage.

Unicla®

Unicla International Limited
Hong Kong: +852 2422 0180
Australia: +61 7 5549 4000

www.unicla.hk
sales@unicla.hk

