



Unicla

Advanced compressor technology for the world



D Group

**Heavy Duty
OE Replacement Compressors**

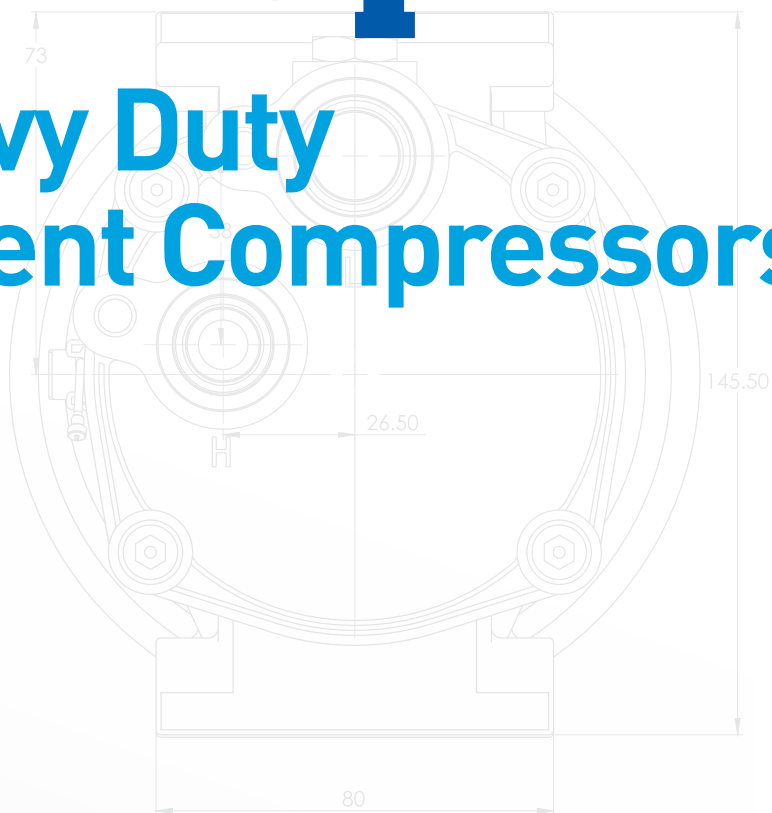



Uniola

Advantages 45 to 200 Series Compressors

All access ports have a common M12x1.0mm port size to allow blanking plugs, service valves, oil return and pressure switch fittings to be interchangeable.

Multi directional rotation – clockwise and anti-clockwise with no change in volumetric efficiency.

Interchangeable rear cap – ease of manufacture for multiple applications

HD impressed steel gasket and HNBR Japanese high temperature O-ring – two point seal

10 cylinder – increase VE in all RPM ranges

Each piston is matched to each cylinder housing by hand

Compressor working assembly is completely separate to the outer housing – heat distortion will never affect piston alignment, overall compression and leakage

HT forged steel cylinder housing

One piece body – no joins

Maximum continuous - 6,000rpm

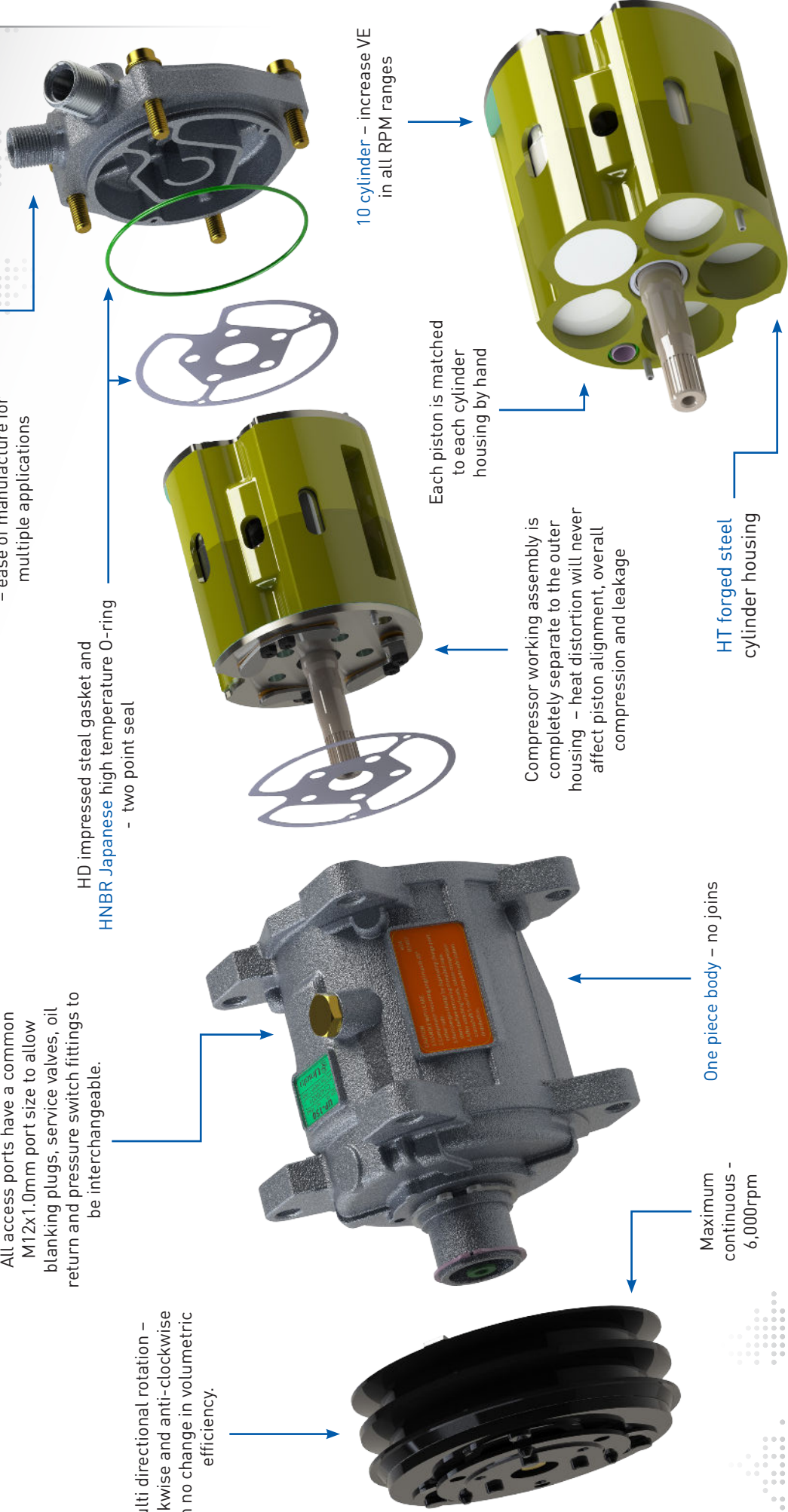



Unicla

UP150-3780

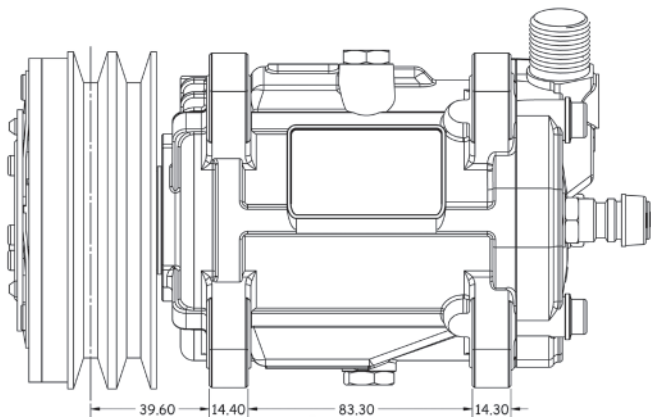
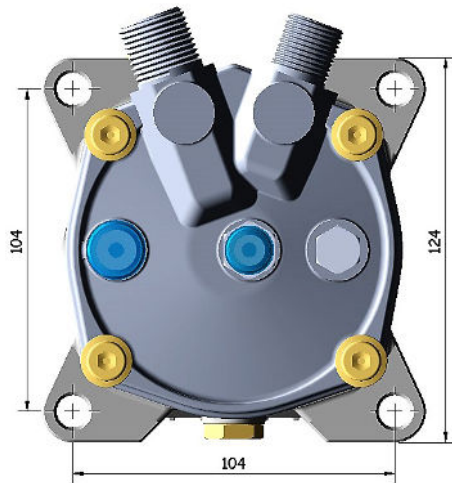

Details

Application

Kenworth truck with ear mount.

Service valves

Low and high side service valves are standard R134a coupler type to conform to SAE J639. These can be removed if required. Use Unicla Part number 13201-000010. High pressure valve fitted.

Fitting options

The top mounted banking plug is interchangeable with oil return fitting - 7/16-20UNF male flare (Part No. 42203-000160).

Hose ports

Placed vertical from the rear and are O-ring type (VOR). Suction port - 7/8-14 UNF (#10) and discharge port - 3/4-16 UNF (#8).

Compressor	
Model	UP150
Part number	UP150-3780
Displacement	145 cc/rev
Max RPM	6,000
Rear cap	VOR
Fitting type	Suction port - 7/8-14UNF Discharge port - 3/4-16UNF
Initial oil charge	160cc

Clutch set	
Part No.	CL109-125
Rating	DC.12, MAX 45W
Revolution	CW/CCW
Belt type	A
Pulley diameter	125mm
Armature No.	CLH109-132



Unicla

UP150-6150

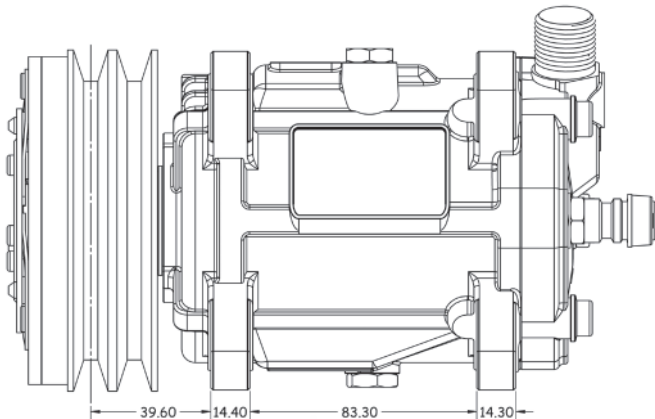
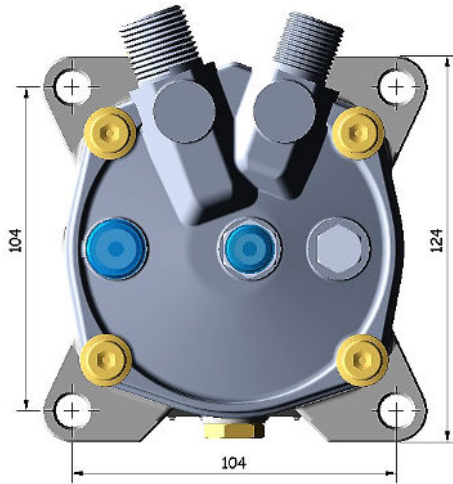

Details

Application

Universal applications, ear mount.

Service valves

Low and high side service valves are standard R134a coupler type to conform to SAE J639. These can be removed if required. Use Unicla Part number 13201-000010.

Fitting options

The top mounted banking plug is interchangeable with oil return fitting - 7/16-20UNF male flare (Part No. 42203-000160).

Hose ports

Placed vertical from the rear and are O-ring type (VOR). Suction port - 7/8-14 UNF (#10) and discharge port - 3/4-16 UNF (#8).

Compressor	
Model	UP150
Part number	UP150-6150
Displacement	145 cc/rev
Max RPM	6,000
Rear cap	VOR
Fitting type	Suction port - 7/8-14UNF Discharge port - 3/4-16UNF
Initial oil charge	160cc

Clutch set	
Part No.	CL109-132
Rating	DC.12, MAX 45W
Revolution	CW/CCW
Belt type	A
Pulley diameter	132mm
Armature No.	CLH109-132



Unicla

UP150-4446

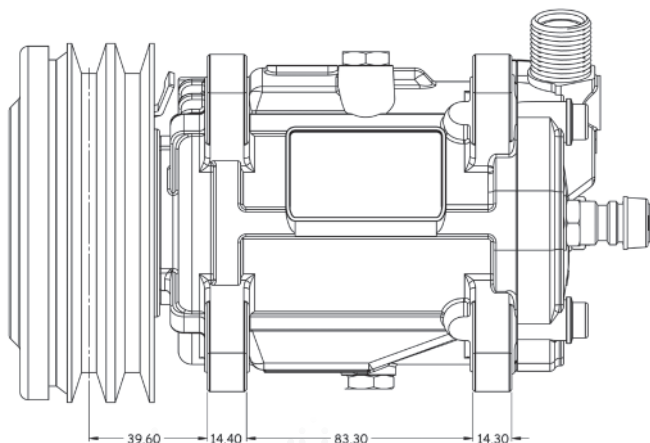
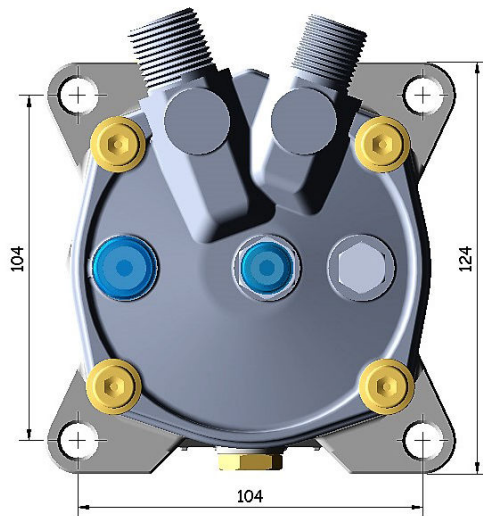

Details

Application

Isuzu F, N series, Scania P113H, 113M, P92M.

Service valves

Low and high side service valves are standard R134a coupler type to conform to SAE J639. These can be removed if required. Use Unicla Part number 13201-000010.

Fitting options

The top mounted banking plug is interchangeable with oil return fitting - 7/16-20UNF male flare (Part No. 42203-000160).

Hose ports

Placed vertical from the rear and are O-ring type (VOR).
Suction port - 7/8-14 UNF (#10) and discharge port - 3/4-16 UNF (#8).

Compressor	
Model	UP150
Part number	UP150-4446
Displacement	145 cc/rev
Max RPM	6,000
Rear cap	VOR
Fitting type	Suction port - 7/8-14UNF Discharge port - 3/4-16UNF
Initial oil charge	160cc

Clutch set	
Part No.	CL109-132-24V
Rating	DC.24v, MAX 45W
Revolution	CW/CCW
Belt type	A
Pulley diameter	132mm with dust cover
Armature No.	CLH109-132



Unicla

US150-4745



Details

Application

Kenworth with direct mount.

Service valves

High pressure relief valve fitted. Service valves are not fitted.

Fitting options

The top mounted banking plug is interchangeable with oil return fitting - 7/16-20UNF male flare (Part No. 42203-000160).

Hose ports

Placed vertical from the rear and are O-ring type (VOR).
Suction port - 7/8-14 UNF (#10) and discharge port - 3/4-16 UNF (#8).

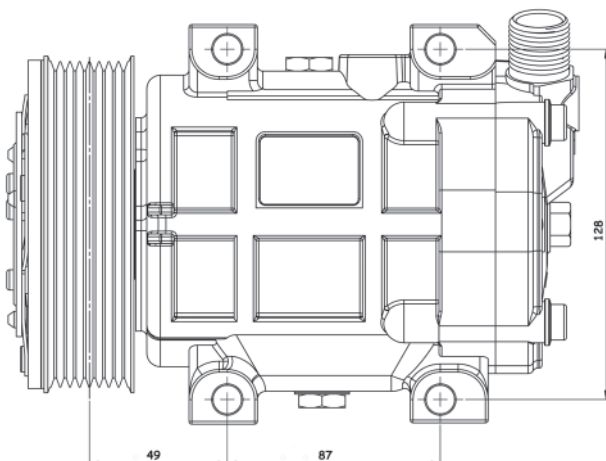

Compressor

Model	US150
Part number	US150-4745
Displacement	145 cc/rev
Max RPM	6,000
Rear cap	VOR
Fitting type	Suction port - 7/8-14UNF Discharge port - 3/4-16UNF
Initial oil charge	160cc

Clutch set

Part No.	27205-001400
Rating	DC.12, MAX 45W
Revolution	CW/CCW
Belt type	8PK
Pulley diameter	119mm
Armature No.	CLH109-132



Unicla

UP150-6157

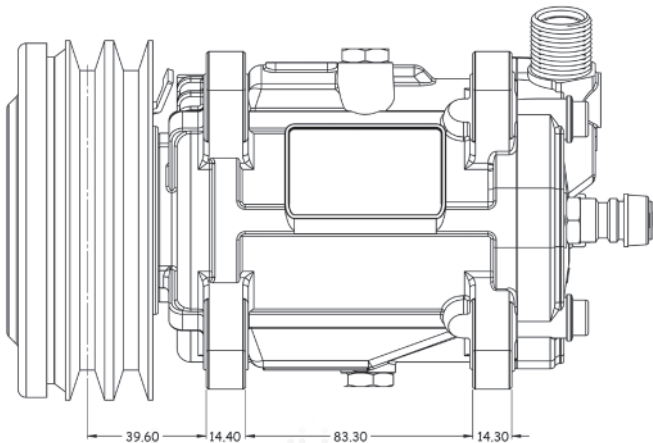
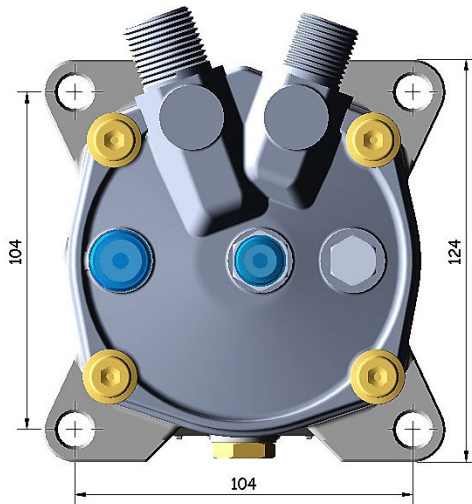

Details

Application

Universal applications, ear mount.

Service valves

Low and high side service valves are standard R134a coupler type to conform to SAE J639. These can be removed if required. Use Unicla Part number 13201-000010.

Fitting options

The top mounted banking plug is interchangeable with oil return fitting - 7/16-20UNF male flare (Part No. 42203-000160).

Hose ports

Placed vertical from the rear and are O-ring type (VOR). Suction port - 7/8-14 UNF (#10) and discharge port - 3/4-16 UNF (#8).

Compressor

Model	UP150
Part number	UP150-6157
Displacement	145 cc/rev
Max RPM	6,000
Rear cap	VOR
Fitting type	Suction port - 7/8-14UNF Discharge port - 3/4-16UNF
Initial oil charge	160cc

Clutch set

Part No.	CL109-132
Rating	DC.12, MAX 45W
Revolution	CW/CCW
Belt type	A
Pulley diameter	132mm with dust cover
Armature No.	CLH109-132



Unicla

UP150-6200

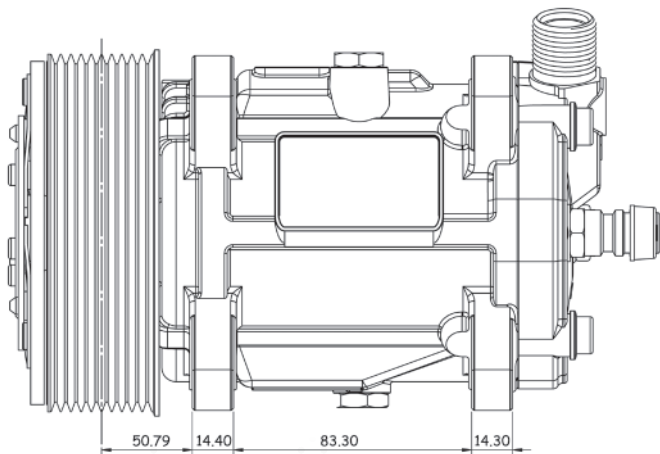
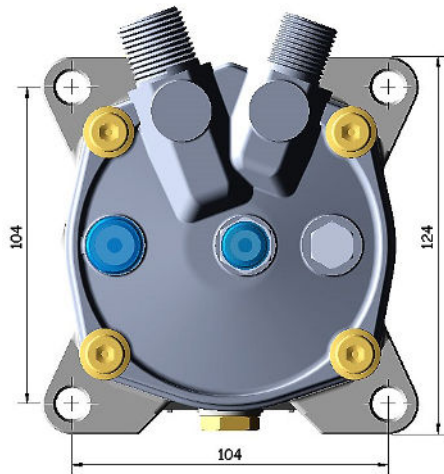

Details

Application

Universal applications, ear mount.

Service valves

Low and high side service valves are standard R134a coupler type to conform to SAE J639. These can be removed if required. Use Unicla Part number 13201-000010.

Fitting options

The top mounted banking plug is interchangeable with oil return fitting - 7/16-20UNF male flare (Part No. 42203-000160).

Hose ports

Placed vertical from the rear and are O-ring type (VOR).
Suction port - 7/8-14 UNF (#10) and discharge port - 3/4-16 UNF (#8).

Compressor

Model	UP150
Part number	UP150-6200
Displacement	145 cc/rev
Max RPM	6,000
Rear cap	VOR
Fitting type	Suction port - 7/8-14UNF Discharge port - 3/4-16UNF
Initial oil charge	160cc

Clutch set

Part No.	CL109R2.5-12V
Rating	DC.12, MAX 45W
Revolution	CW/CCW
Belt type	10PK
Pulley diameter	125mm
Armature No.	CLH109-132



Unicla

UP150-7325

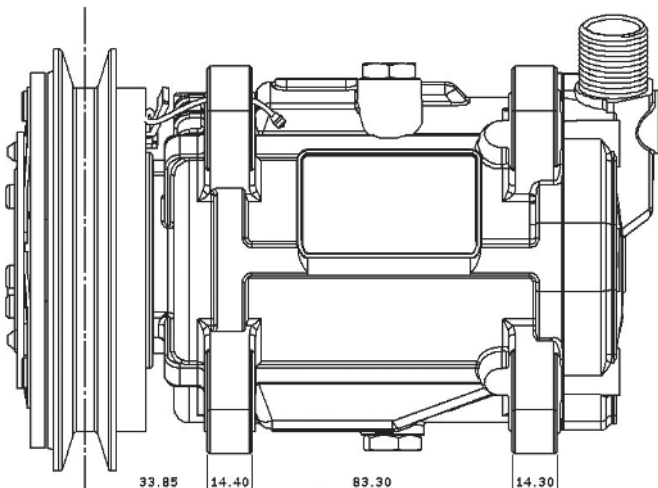
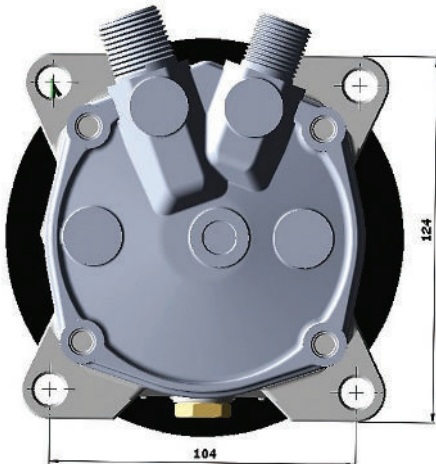

Details

Application

Sandvik F9C, L7 Drills and universal applications.

Service valves

Service and high pressure relief valves are not fitted.

Fitting options

The top mounted banking plug is interchangeable with oil return fitting - 7/16-20UNF male flare (Part No. 42203-000160).

Hose ports

Placed vertical from the rear and are O-ring type (VOR).
Suction port - 7/8-14 UNF (#10) and discharge port - 3/4-16 UNF (#8).

Compressor

Model	UP150
Part number	UP150-7325
Displacement	145 cc/rev
Max RPM	6,000
Rear cap	VOR
Fitting type	Suction port - 7/8-14UNF Discharge port - 3/4-16UNF
Initial oil charge	160cc

Clutch set

Part No.	27205-001870
Rating	DC.24v, MAX 45W
Revolution	CW/CCW
Belt type	B
Pulley diameter	146mm
Armature No.	CLH109-132



Unicla

UP150-7335

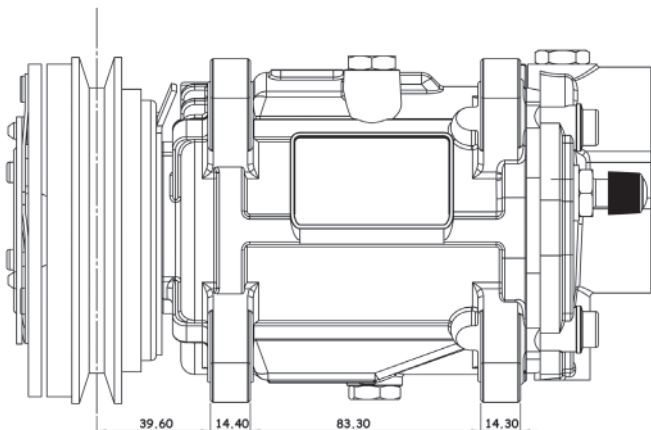
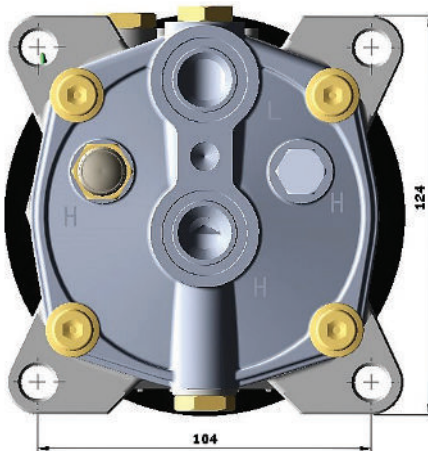
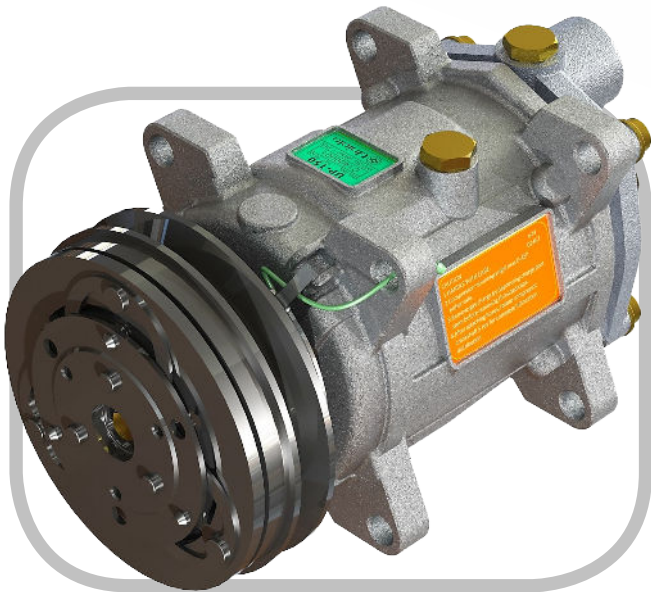

Details

Application

Cat Graders, Dump Trucks, Scrapers, Dozers, Loaders with Ear Mount.

Service valves

7/16-20 UNF male flare with valve core fitted for high side pressure switch access (Part No. 42203-000150)
High pressure relief valve fitted. Service valves are not fitted.

Fitting options

The top mounted banking plug is interchangeable with oil return fitting - 7/16-20UNF male flare (Part No. 42203-000160).

Hose ports

GM pad type placed horizontal (outward) from the rear cap in vertical position with suction on the top. Suction port - 13mm OD and discharge port - 10mm OD.

Compressor	
Model	UP150
Part number	UP150-7335
Displacement	145 cc/rev
Max RPM	6,000
Rear cap	GM Pad
Fitting type	Pad O-ring
Initial oil charge	160cc

Clutch set	
Part No.	27205-001880
Rating	DC.24v, MAX 45W
Revolution	CW/CCW
Belt type	A
Pulley diameter	138.5mm with dust cover
Armature No.	CLH109-132



Unicla

UP150-7355

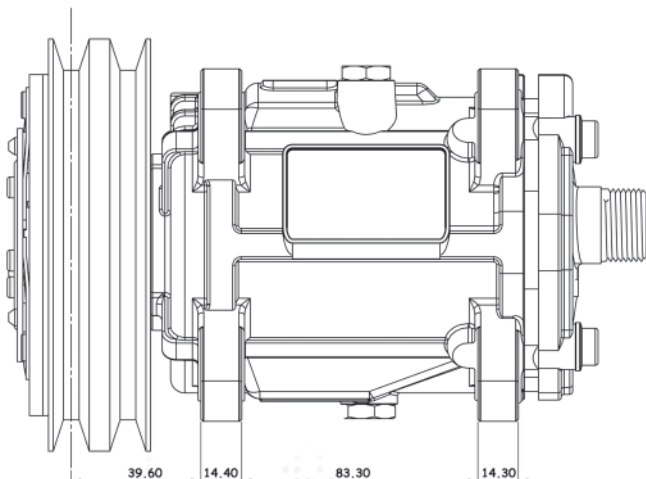
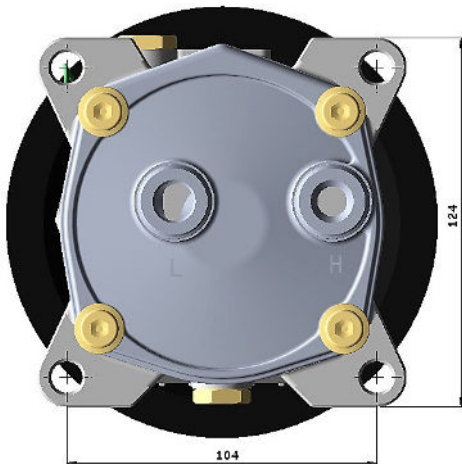
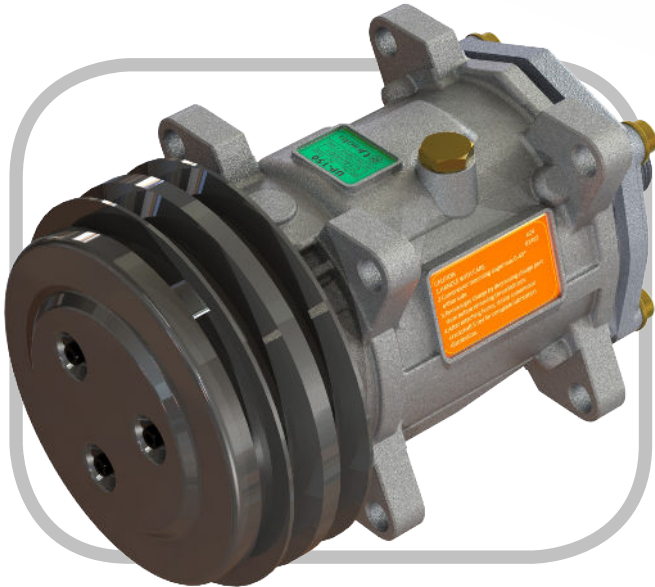

Details

Application

Case IH tractors.

Service valves

Service and high pressure relief valves are not fitted.

Fitting options

The top mounted banking plug is interchangeable with oil return fitting - 7/16-20UNF male flare (Part No. 42203-000160).

Hose ports

Placed horizontal (outward) from the rear cap - tube O-ring type. Suction and discharge port connections both - 1-14 UNS.

Compressor

Model	UP150
Part number	UP150-7355
Displacement	145 cc/rev
Max RPM	6,000
Rear cap	HTO
Fitting type	Tube O-ring
Initial oil charge	160cc

Clutch set

Part No.	27205-001900
Rating	DC.12, MAX 45W
Revolution	CW/CCW
Belt type	A
Pulley diameter	152mm with dust cover
Armature No.	CLH109-132



Unicla

US150-7365

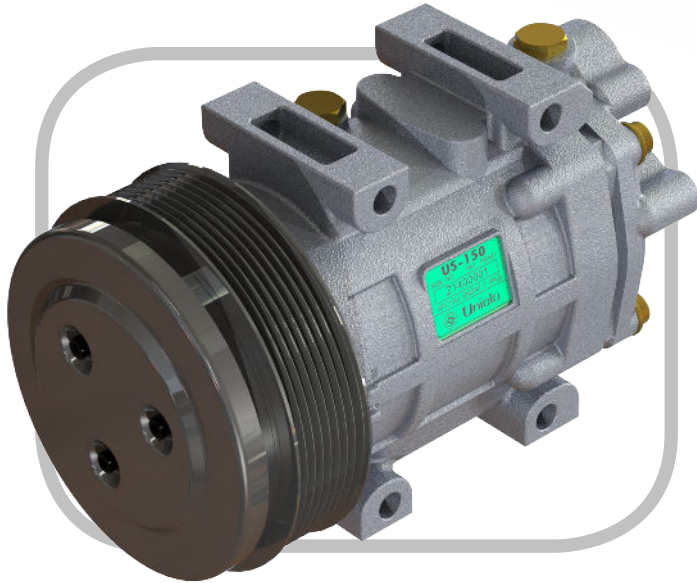

Details

Application

Volvo truck and bus.

Service valves

Service and high pressure relief valves are not fitted.

Fitting options

The top mounted banking plug is interchangeable with oil return fitting - 7/16-20UNF male flare (Part No. 42203-000160).

Hose ports

Special horizontal pad type at rear cap (outward) on LHS.

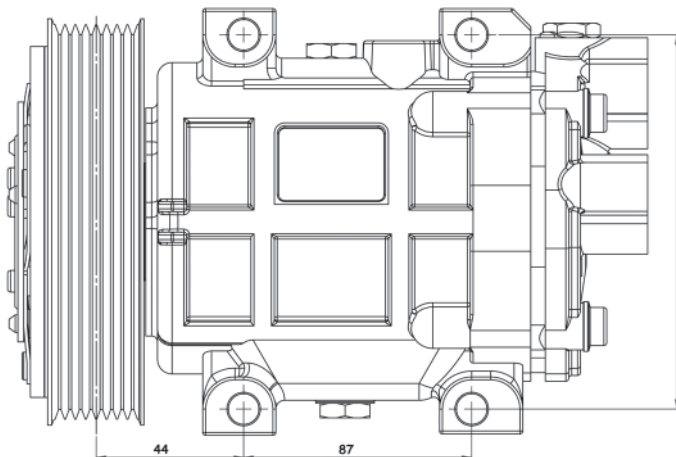
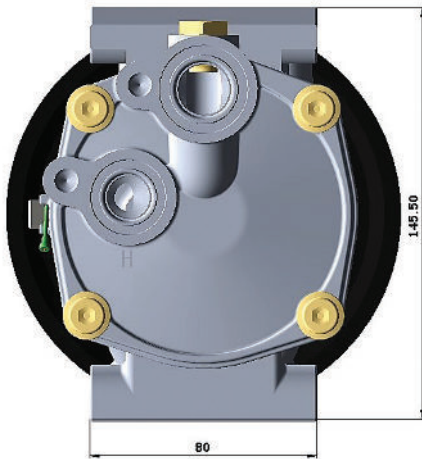

Compressor

Model	UP150
Part number	UP150-7365
Displacement	145 cc/rev
Max RPM	6,000
Rear cap	Individual Pad
Fitting type	Pad O-ring
Initial oil charge	160cc

Clutch set

Part No.	27205-001910
Rating	DC.24v, MAX 45W
Revolution	CW/CCW
Belt type	8PK
Pulley diameter	133mm
Armature No.	CLH109-132



Unicla

US150-7375

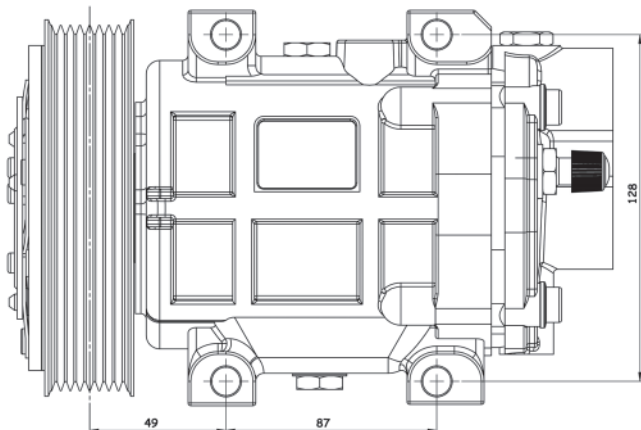
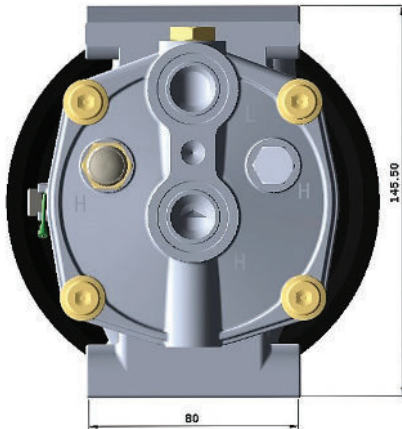

Details

Application

Cat graders, dump trucks, scrapers, dozers, loaders with direct mount.

Service valves

High pressure relief valve fitted. Service valves are not fitted.

Fitting options

The top mounted banking plug is interchangeable with oil return fitting - 7/16-20UNF male flare (Part No. 42203-000160).

Hose ports

GM pad type placed horizontal (outward) from the rear cap in vertical position with suction on the top. Suction port - 13mm OD and discharge port - 10mm OD.

Compressor	
Model	US150
Part number	US150-7375
Displacement	145 cc/rev
Max RPM	6,000
Rear cap	GM Pad
Fitting type	Pad O-ring
Initial oil charge	160cc

Clutch set	
Part No.	27205-001920
Rating	DC.24v, MAX 45W
Revolution	CW/CCW
Belt type	8PK
Pulley diameter	133mm
Armature No.	CLH109-132



Unicla

US150-7385

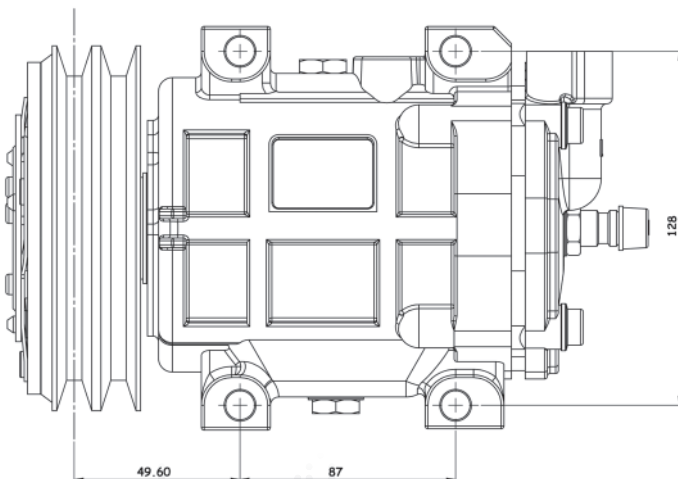

Details

Application

Isuzu N series direct mount.

Service valves

Service and high pressure relief valves are not fitted.

Fitting options

The top mounted banking plug is interchangeable with oil return fitting - 7/16-20UNF male flare (Part No. 42203-000160).

Hose ports

Common pad type placed vertical (upward) from the rear cap. Suction port - 13mm OD and discharge port - 10mm OD.

Compressor

Model	US150
Part number	US150-7385
Displacement	145 cc/rev
Max RPM	6,000
Rear cap	Top Pad
Fitting type	Pad O-ring
Initial oil charge	160cc

Clutch set

Part No.	27205-001930
Rating	DC.24v. MAX 45W
Revolution	CW/CCW
Belt type	A
Pulley diameter	132mm
Armature No.	CLH109-132



Unicla

UV150-7615



Details

Application

Hitachi excavators ZX2000, ZX200LC.

Service valves

High pressure relief valve fitted. Service valves are not fitted.

Fitting options

The top mounted banking plug is interchangeable with oil return fitting - 7/16-20UNF male flare (Part No. 42203-000160).

Hose ports

Special pad type placed vertical (upward) at rear cap.

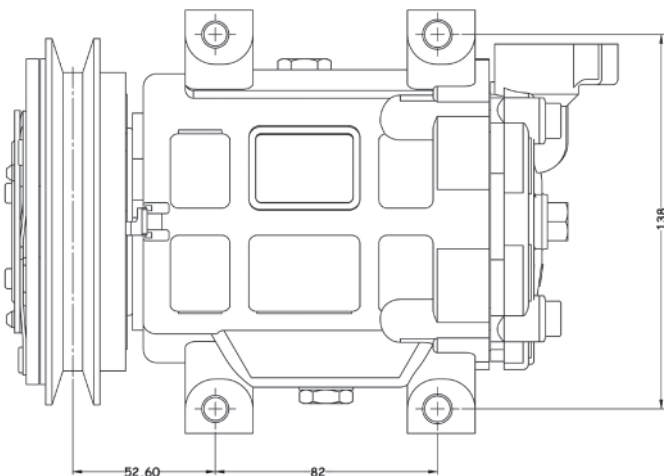
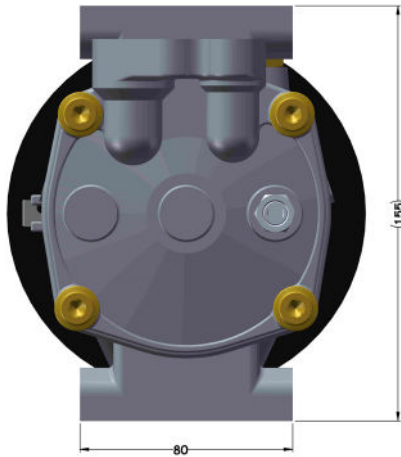

Compressor	
Model	UV150
Part number	UV150-7615
Displacement	145 cc/rev
Max RPM	6,000
Rear cap	Vertical pad
Fitting type	Pad O-Ring
Initial oil charge	160cc

Clutch set	
Part No.	27201-00470
Rating	DC.24, MAX 45W
Revolution	CW/CCW
Belt type	B
Pulley diameter	137mm
Armature No.	CLH109-132



Part Number	Application	Clutch	End Cap	Oil
UP150-3780	Kenworth with Ear Mount	12v 125mm AA	VOR #8, #10 with HPRV	160ml PAG
UP150-6150	Universal Applications, Ear Mount	12v 132mm AA	VOR #8, #10	160ml PAG
UP150-4446	Isuzu F, N series, Scania P113H, 113M, P92M	24v 132mm AA with Dust Cover	VOR #8, #10	160ml PAG
US150-4745	Kenworth with Direct Mount	12v 119mm 8PV	VOR #8, #10	160ml PAG
UP150-6157	Universal Applications, Ear Mount	12v 132mm AA with Dust Cover	VOR #8, #10	160ml PAG
UP150-6200	Universal Applications, Ear Mount	12v 125mm 10PV	VOR #8, #10 with HPRV	160ml PAG
UP150-7325	Sandvik F9C, L7 Drills and Universal Applications	24v 146mm 1B	VOR #8, #10	160ml PAG
UP150-7335	Cat Graders, Dump Trucks, Scrapers, Dozers, Loaders with Ear Mount	24v 138.5mm 1A with Dust Cover	Horizontal Pad (GM) with HPRV	160ml PAG
UP150-7355	Case IH Tractors	24v 152mm AA with Dust Cover	HTO Fittings	160ml PAG
US150-7365	Volvo Truck and Bus	24v 132mm 8PV	Horizontal Pad with HPRV	160ml PAG
US150-7375	Cat Graders, Dump Trucks, Scrapers, Dozers, Loaders with Direct Mount	24v 133mm 8PV	Horizontal Pad (GM) with HPRV	160ml PAG
US150-7385	Isuzu N Series Direct Mount	24v 132mm AA	Vertical Pad to suit Isuzu	160ml PAG
UV150-7615	Hitachi Excavators ZX200, ZX200LC	24v 137mm 1B	Vertical Pad to suit Hitachiz	160ml PAG



HEAD OFFICE

Unicla International Limited

Unit 1109, 11/F, Manhattan Centre, 8 Kwai Cheong Road,
Kwai Chung, N.T., Hong Kong

PHONE: +852 2422 0180

FAX: +852 2422 0680

EMAIL: sales@unicla.hk

www.unicla.hk

Unicla Australia

14 Motorway Circuit Ormeau,
Queensland 4208 Australia

PHONE: +61 7 5549 4033

FAX: +61 7 5549 4044

EMAIL: sales@unicla.hk

www.unicla.hk