



Unicla

UWX SERIES
INSTALLATION
GUIDELINES



Unicla

Copyright © 2019 All rights reserved

No part of this document shall be reproduced in whole or in part without the permission of Unicla International Limited. This includes reproduction or copies in any form or by any means including photocopying, printing or electronic media.

IMPORTANT DISCLAIMER

This is a guideline document containing professional information using representative graphs, charts and tables. Manufacturers' specifications must be consulted for specific guidelines and performance data. Unicla published data, specific to all models, is available in promotional literature and from Unicla International Limited on request or through your Unicla supplier. Unicla International Ltd expressly disclaims all and any liability and responsibility to any person or business as a result of any actions taken on the basis of information in this publication.

Table of Contents

1. Initial handling.....	1
2. System cleanliness.....	1
3. Fitting of discharge hose manifold.....	2
4. Mounting angle.....	3
5. System oil quantity requirement.....	3
6. Oil type and grade.....	4
7. Compressor oil level.....	4
8. Compressor sight glass visualisation and diagnosis.....	5
9. Recommended suction line pipe size.....	6
10. Compressor speed.....	6
11. In-line suction filter and screen.....	7
12. Oil injector.....	7
13. Refrigerant charging.....	8
14. Thermal and pressure checks after commissioning.....	9
15. Pressure switches.....	11
16. Oil separators.....	12
17. Compressor operation analysis report.....	13
18. Installation and commissioning checklist.....	14
19. Notes.....	15

This booklet is designed to assist the installing technician to ensure Unicla guidelines and procedures have been followed during the installation and initial commissioning of UWX series compressors.

For further and detailed information regarding system oil analysis and flow, please refer to:

Unicla booklet B1801

The importance of suction lines: Analysis and connection to compressors

Unicla booklet B1802

Oil and compressor lubrication

Unicla booklet B0801

General service information

1. Initial handling

a) Removing transit gas (from discharge service valve or pressure switch port if fitted)

Before mounting and when handling a new Unicla UWX compressor for the first time, remove the dust cap from the discharge service valve and gently release the gas as shown in Figure 1.

TAKE CARE TO NOT LET OIL ESCAPE.

NOTE: Do not add refrigerant to the system from these ports.



Figure 1. Remove transit gas via discharge service valve or pressure switch port (if fitted). Use a small screw driver or any tool with a pointy end to depress the Schroeder valve.

b) Initial lubrication

Using a 14 mm wrench or socket, rotate the compressor armature manually for 4-5 revolutions to ensure proper lubrication to the working assembly components as shown in Figure 2. This will avoid damage during initial start up. This procedure is best to do when the compressor is removed from its packaging, and repeated after all hoses in the system and compressor are connected.

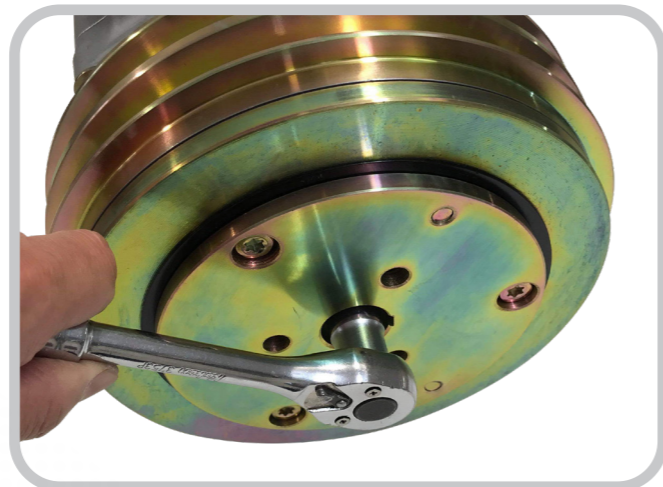

Figure 2. Rotate armature manually.

2. System cleanliness

a) Contamination

The system must be free of both solid particle and chemical contamination before fitting the new compressor. Solid particle contamination will cause direct compressor damage and starvation due to blocked system filters and screens (see Section 11). Chemical contamination can reduce solubility/miscibility of refrigerants and oils, reduce oil viscosity, and cause acid etching and sludge formation.

b) Flushing

Contaminated systems must be flushed before fitting the new compressor. Individual component flushing is strongly recommended in systems where solid particle contamination has occurred during the system assembly process. The compressor, TX valve, pressure control valves, receiver driers/accumulators and mufflers/pulsation dampers **must not be flushed.**

3. Fitting the discharge hose manifold

- Choose either left or right hand discharge port
- Remove shipping cap from discharge port to be used

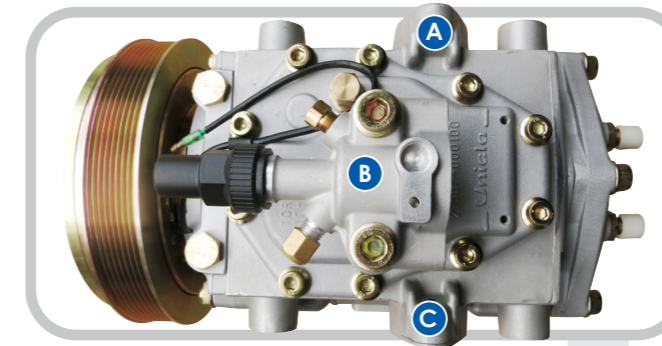

a) Port position

- A Discharge port (left side)
- B Manifold valve (suction port)
- C Discharge port (right side)

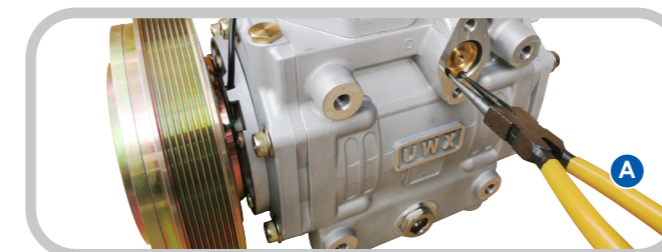

b) Remove the snap ring from the port plug

- A Snap ring pliers

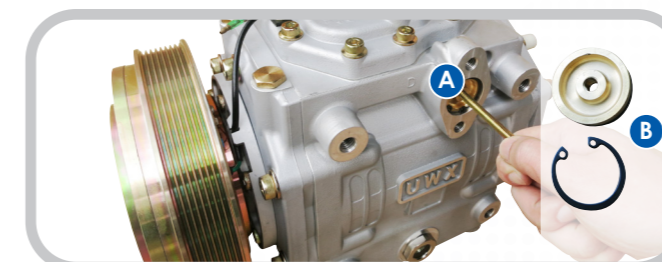

c) Remove the port plug

- A Screw an M6 x L65 bolt into the port plug and use it to pull out the plug
- B Removed parts: Plug and snap ring

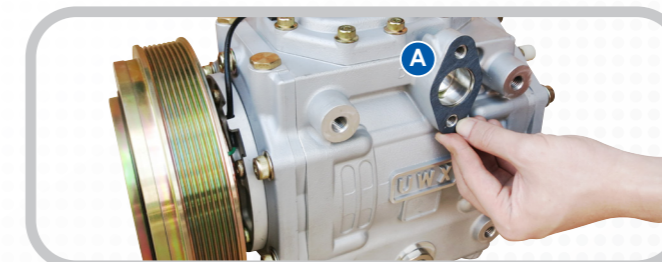

d) Install the gasket

- A Gasket

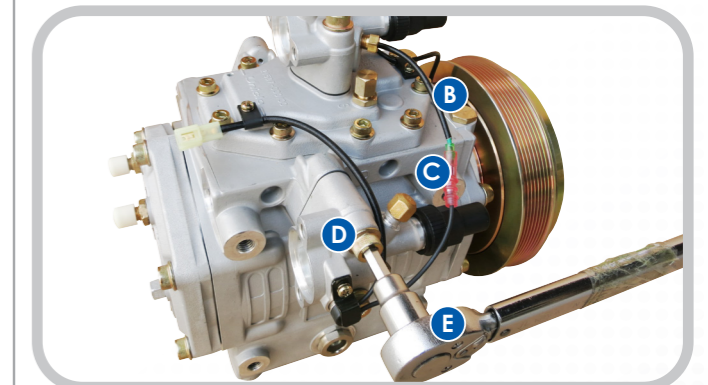
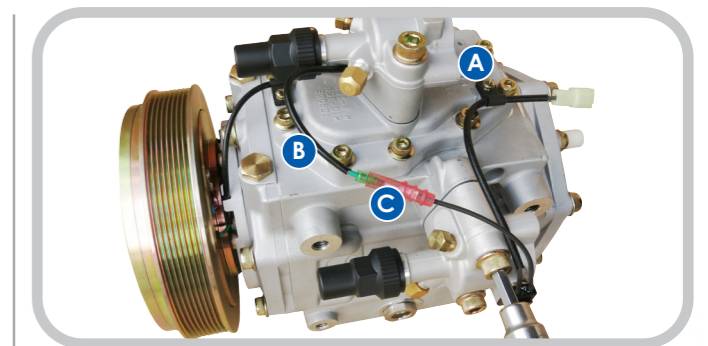

e) Install manifold valve (on right or left side)

- A Clamp fixed
- B Clutch wire
- C Sensor wire
- D M10 x L60 bolt (x2)
- E Tighten to 34.3 Nm (350 kg/cm)

Connect the clutch wire to the sensor on the discharge manifold valve before operation.

WARNING: Do not directly connect the power cord to the clutch wire.

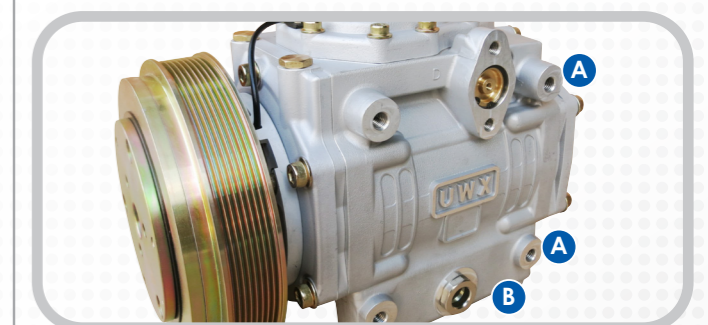

f) Mounting direction

- A The side mounting
 - B The bottom mounting
- M12 x P (2 x 4) = 1.75 M12 (x4) x P = 1.75

CAUTION: Compressor should be mounted on its bracket from all points located at the bottom and at least one side where the discharge hose manifold is not fitted.

4. Mounting angle

The limits for mounting Unicla UWX compressors are described in the following diagrams:

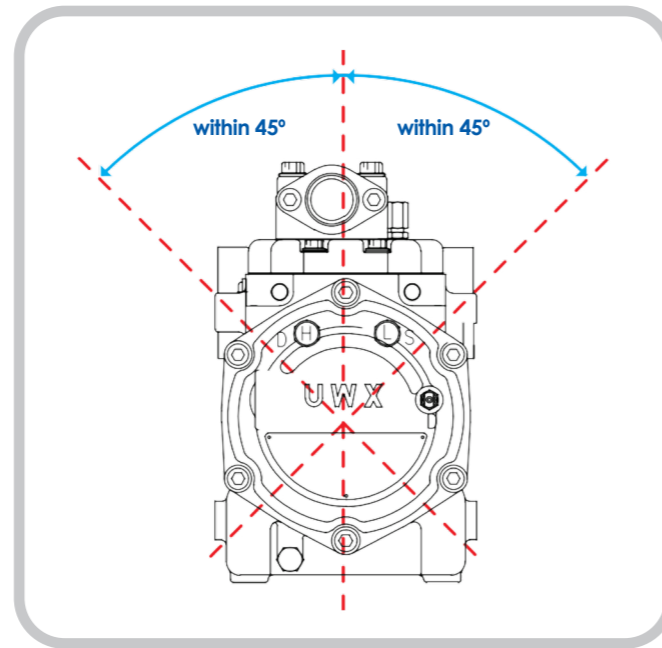
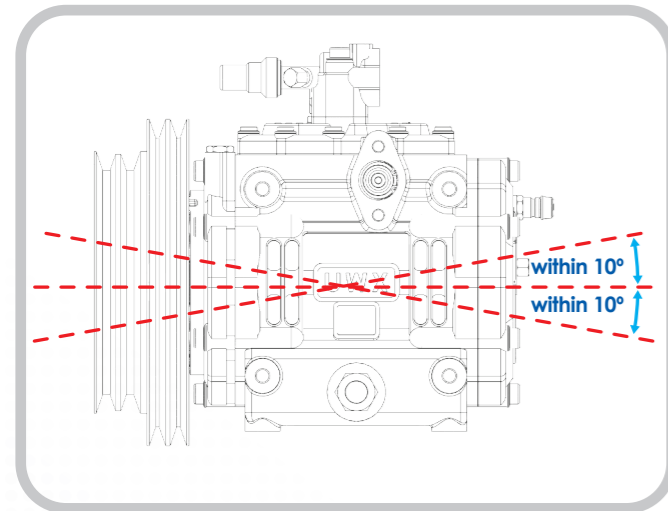

5. System oil quality requirements

The correct amount of oil must exist in the system to ensure the correct mixture ratio of oil and refrigerant flows back to the compressor. To achieve this, the total oil quantity that needs adding to the system is described in the following chart:

Total refrigerant in system	Oil quantity to add – if suction line < 6 metres in length	Oil quantity to add – if suction line > 6 metres in length
5.0 kg	Nil	500 cc
5.5 kg	100 cc	650 cc
6.0 kg	200 cc	800 cc
6.5 kg	300 cc	950 cc
7.0 kg	400 cc	1100 cc
7.5 kg	1250 cc	1250 cc
8.0 kg	1400 cc	1400 cc

NOTE: Oil quantity recommendations are in addition to the oil installed in the compressor. Unicla UWX440, UWX550 and UWX660 series compressors are fitted with 1000cc of oil as standard, and this amount is **excluded** from the quantities recommended above.

NOTE: Oil quantity calculations are contained in the Unicla Service Handbook. The total system oil requirement is based on 20% and 30% of refrigerant charges for systems with < 6m suction line and > 6m suction line respectively.

Larger capacity systems holding > 7.0 kg of refrigerant are deemed to require the maximum oil quantity (30% of refrigerant charge) due to the potential size of the heat exchangers and hose runs holding extra system oil.

6. Oil type and grade

Each Unicla UWX440, UWX550 and UWX660 compressor is fitted with either PAG oil (Unidap 7) or POE oil (Unidap 6). When adding oil to the system, Unicla oil must be used.

Compressor model	Refrigerant	Oil type (Unicla)	Viscosity @ 40°C	Viscosity @ 100°C	Application	Low side saturation	Oil separator
UWX	R134a	Unidap 7	48.01	10.51	Air-conditioning	>0°C	Optional
UWX	R134a	Unidap 6	65.50	9.30	Air-conditioning	>0°C	Optional
UWXF	R404a	Unidap 3	32.50	5.80	Refrigeration	< -15°C	Required

Alternatively if Unidap oil is not available at the time of installation, then a suitable known brand of oil can be used as described in the following chart.

NOTE: The correct amount and grade of oil must be maintained in the compressor and system. Failure to comply with this may result in dramatically reduced oil circulation rates with subsequent starvation of the compressor.

Recommended alternatives for Unicla Lubricant:

Unicla oil type	Alternative
Unidap 6	POE 68
Unidap 7	PAG 56
Unidap 3	POE 32

WARRANTY IS VOID IF THESE GUIDELINES ARE NOT FOLLOWED.

The following labels will determine the type of oil in each UWX compressor:

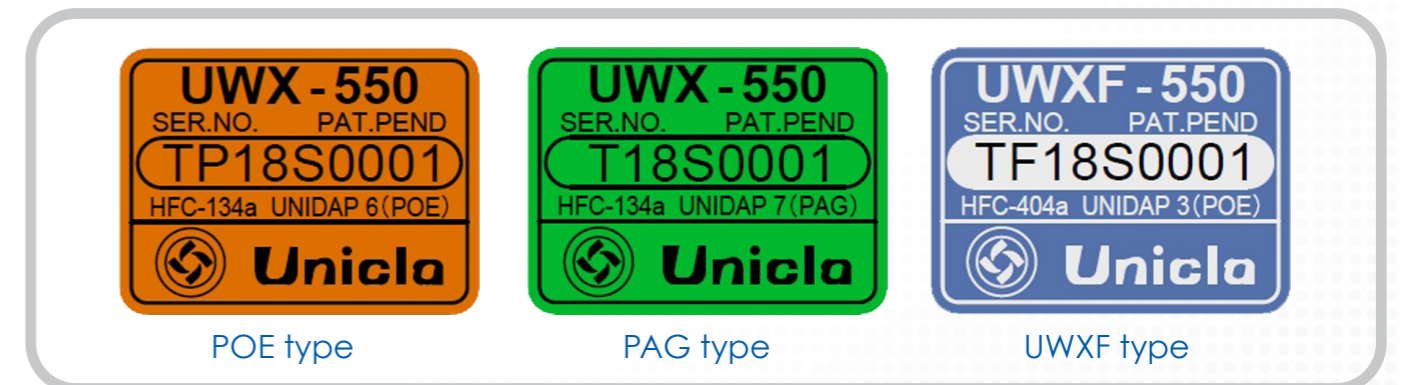

7. Compressor oil level

NOTE: This diagram shows oil level quantities at the sight glass to indicate actual oil level in the sump.

700 cc - 1000 cc to top of sump (**Normal**)
 400 cc to top of sight glass (**Low**)
 200 cc to centre of sight glass (**Low**)

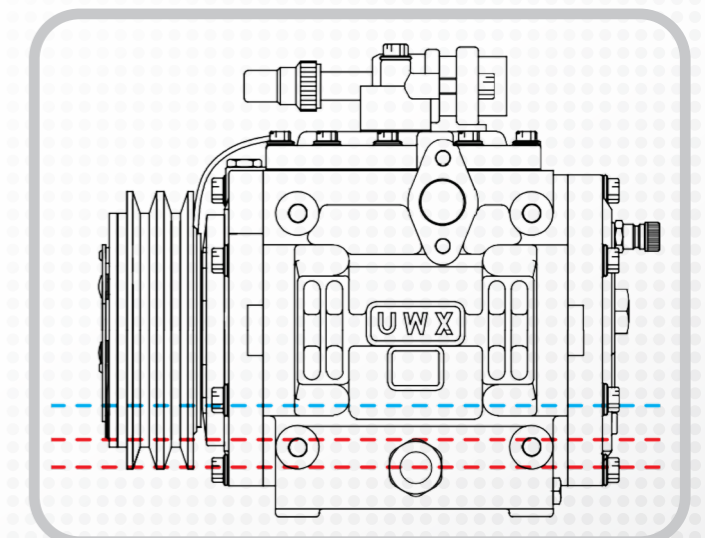

8. Compressor sight glass visualisation and diagnosis

The following chart and images will assist the technician to check the sight glass of the compressor after commissioning the system. Different operating conditions will present variable symptoms to appear at the sight glass and Unicla recommends this must be checked both immediately after commissioning and at future regular intervals during service.

To obtain the best possible visual of the sight glass, it is recommended the rear sight glass is back lit with a good quality white light, preferably from an LED torch or headlight. This will produce good light through the centre of the compressor sump to allow accurate evaluation of the oil level and quality.

Visual	Sight glass	Oil	Operation	Recommendation
	Normal > high point	Normal - clear and transparent	OK	Nil
	Normal > high point	Possible slight moisture contamination or high temperature operation	OK	Monitor oil condition and change if necessary
	Normal > high point	Green slime: Copper hydroxide present	OK	Monitor oil condition and change if necessary
	Oil level low < half point	Normal: Clean and transparent, dark section is oil foam rather than contamination	Oil flow or level is low	Check suction pressure and system oil quantity
	Oil level low < half point	Normal: Clean and slight orange or red colour	Oil flow or level is low and running at high temperature	Check suction pressure and system oil quantity
	Oil level < low point	Not visible	Oil flow or level is critically low: Damage to compressor will occur Suction pressure is most likely at 1.0 bar (14 psi) or less and must be rectified	Cease system operation and check suction pressure and system oil quantity
	Normal > high point	Black and cloudy: Severely contaminated	Compressor will fail	Cease system operation. Clean and flush system, replace compressor oil
	Oil level < high point	Dark black: Severely contaminated and has black sludge	Compressor will fail	Cease system operation. Clean and flush system, replace compressor oil

9. Recommended suction line pipe size

The following chart gives the suction pipe size recommendations for Unicla 440/550/660 series compressors.

UWX440/550/660 compressors	3 m Pipe length			6 m Pipe length			10 m Pipe length			12 m Pipe length			18 m Pipe length		
	RPM	Temp Diff (K)	Press Diff (kPa)	Pipe size mm (inch)	Temp Diff (K)	Press Diff (kPa)	Pipe size mm (inch)	Temp Diff (K)	Press Diff (kPa)	Pipe size mm (inch)	Temp Diff (K)	Press Diff (kPa)	Pipe size mm (inch)	Temp Diff (K)	Press Diff (kPa)
1000	0.55	5.7	22 (7/8)	0.29	3	26 (1 1/8)	0.48	5	28 (1 1/8)	0.58	6	28 (1 1/8)	0.87	8.9	28 (1 1/8)
1500	0.29	3	28 (1 1/8)	0.58	6	28 (1 1/8)	0.98	10	28 (1 1/8)	0.41	4.2	35 (1 3/8)	0.61	6.3	35 (1 3/8)
2000	0.29	3	28 (1 1/8)	0.94	9.6	28 (1 1/8)	0.54	5.6	35 (1 3/8)	0.65	6.7	35 (1 3/8)	0.99	10.1	35 (1 3/8)
2500	0.64	6.5	28 (1 1/8)	0.44	4.5	35 (1 3/8)	0.74	7.6	35 (1 3/8)	0.89	9.1	35 (1 3/8)	0.56	5.7	41 (1 5/8)

These recommendations must be strictly adhered to ensure adequate refrigerant and oil flow back to the compressor. An undersized suction line will cause a pressure drop between the evaporator outlet and the compressor, and create poor refrigerant and oil flow at the compressor. Particularly at high revs and low evaporator temperatures. For more detailed suction line information refer to *Unicla booklet B1801 - The importance of suction lines: Analysis and connection to compressors*.

10. Compressor speed

The following chart gives the Unicla speed recommendation for UWX440, UWX550 and UWX660 compressors. This **must** be strictly followed at all times.

Compressor series	Ideal operation speed (rpm)	Maximum continuous rpm	Maximum momentary rpm
440/550/660	1200 - 2500	3000	4500

11. Inline suction mesh screen and filter insert

The Unicla inline mesh screen and filter insert should be used whenever there is risk of debris and fine particles entering the compressor through the suction line.

Unicla Suction Filter Insert Part No. 43701-000290

Must be used in conjunction with Unicla Suction Mesh Screen, and **must** be removed after 2-12 hours since initial commissioning. This is ideal for removal of fine particles from a new system.



In the case of older systems where the compressor is replacing a previous failure, the system **must** be flushed and the filter strictly monitored to ensure a blockage does not occur. More than one filter may be required over several hours to properly clean the particles in the suction line.

Unicla Suction Mesh Screen Part No. 43701-000270

Can be left in place in the suction port to ensure continual removal of heavier particles in the system. However, regular inspections of this mesh screen **must** take place to ensure a permanent blockage does not occur.



12. Unicla oil injector

Part No. OIRA803

Unicla oil injector can be used to add additional system oil during the evacuation or refrigerant charging process. Alternatively, any similar injection device can be used.

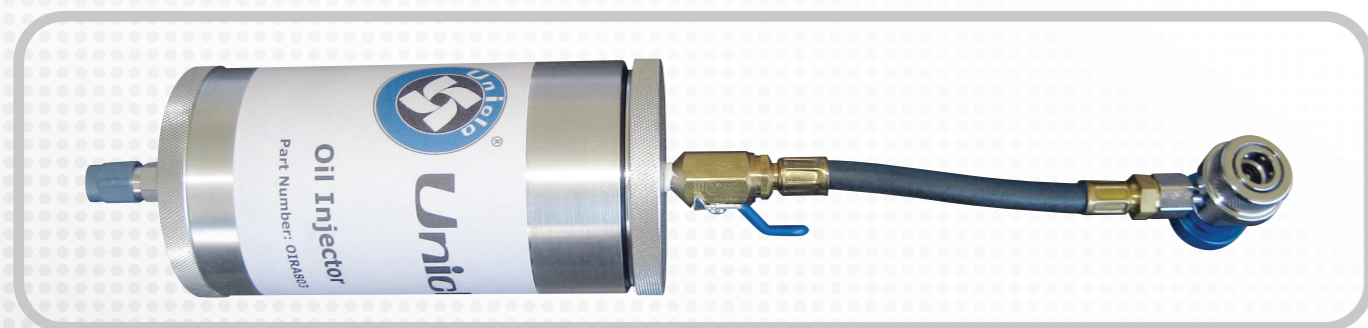

13. Refrigerant charging

When charging the air-conditioning system with refrigerant, it is important that oil is not pushed or washed away from the sump of the compressor; otherwise immediate damage to the compressor internal assembly will occur. To avoid this situation, the position of entry for the refrigerant to the compressor and system must be considered as follows:

- Most bus and coach applications have a system layout with the evaporator on the roof or at least in a position that is higher than the compressor. The preferred procedure for adding refrigerant and oil to the system is at this higher point. This will ensure the correct flow of refrigerant vapour and oil will pass through the compressor without any adverse effects to its initial operation.
- If it is not possible to access the system at the evaporator or roof level, then service points in suction and discharge lines away from the compressor are the next best option.
- If refrigerant must be added at the compressor, and there is no other alternative, only refrigerant vapour is to be added at the discharge and suction manifold valves at the side and top of the compressor (see diagram below).
- Under no circumstances is refrigerant to be added at the R134a coupling service valves (if fitted) on the rear cap of the compressor. These valves are used for diagnosis only.

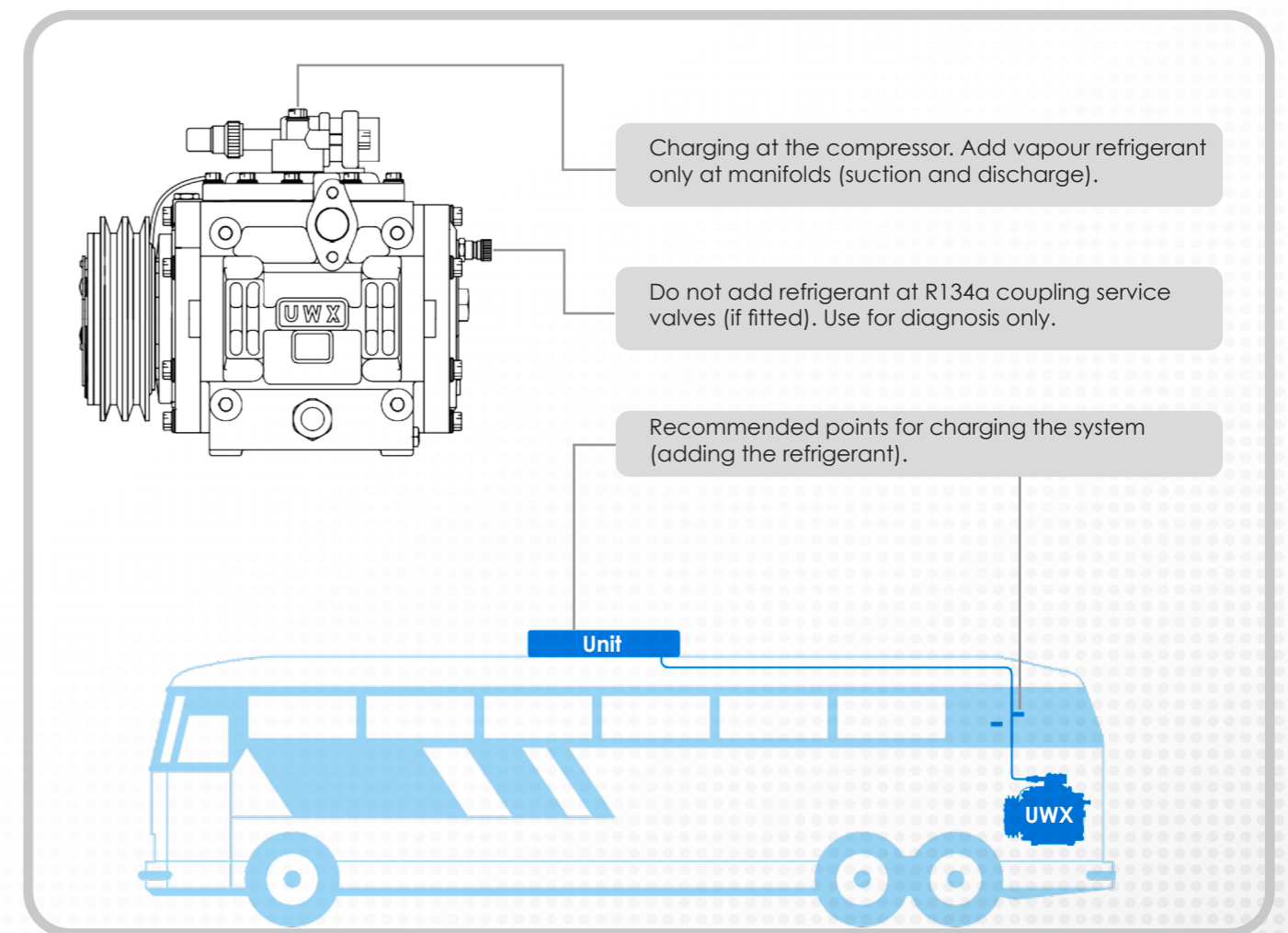

14. Thermal and pressure checks after commissioning

After commissioning a Unicla UWX compressor for the first time, some basic pressure and thermal loading checks will determine if the operating environment for the compressor is within Unicla specifications, and whether compressor durability is being maximised.

Three main checks of the compressor are required:

a) Suction line validation

Analysis of the suction line is important to establish the correct flow of refrigerant and oil back to the compressor. It is also a good indicator that the system has the correct refrigerant charge and is operating at its potential capacity. This is done by completing a superheat calculation at the compressor suction inlet. If superheat levels exceed the range of 6-15K, corrective action is required. Further technical advice and assistance is available by referring to *Unicla Booklet B1801 – The Importance of Suction Lines: Analysis and Connection to Compressors*.

Procedure to calculate suction superheat:

- 1 Measure pressure** at compressor suction line inlet.
Example: Gauge pressure = 1.82 bar (26.40 psi)
- 2 Measure temperature** at compressor suction line inlet. Use an accurate thermocouple clamped securely to the pipe and insulated with cork or foil tape.
Example: 9.0°C (48.2°F)
- 3 Complete superheat calculation** by converting the suction line pressure from Step 1 into temperature (refer to *Pressure/Temperature saturation table – R134a*) and deducting it from the temperature measured on the suction line in Step 2.

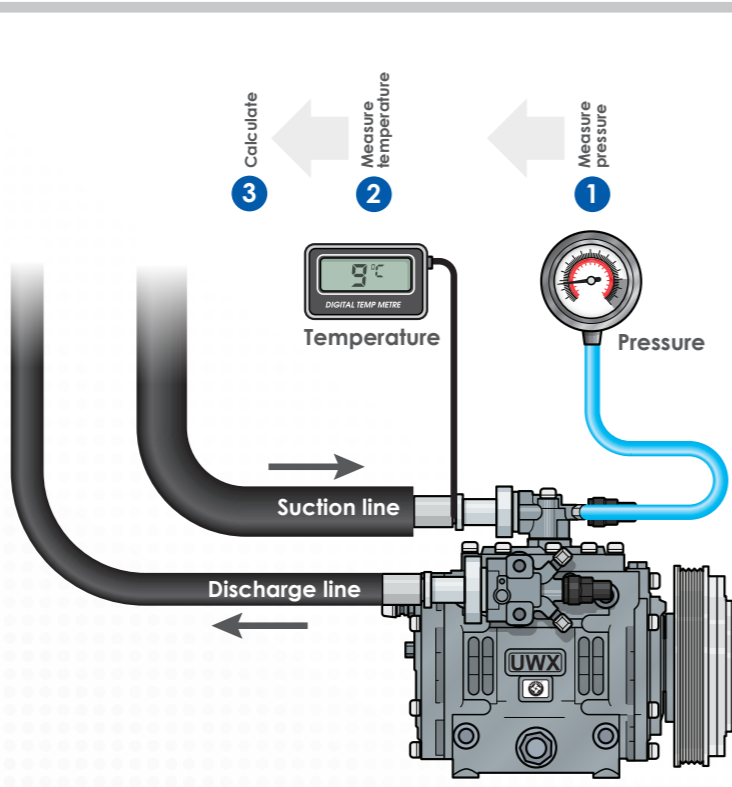

Example:

Step 1: 1.82 bar (26.40 psi) = -1.0°C
 Step 2: = 9.0°C (48.20°F)
 Step 3: = (9.0°C) – (-1.0°C) = 10K

To calculate super heat from Fahrenheit convert to Kelvin scale as follows:

Step 1: 1.82 bar (26.40 psi) = 30.2°F = 272K
 Step 2: = 9.0°C = 48.20°F = 282K
 Step 3: = 282K – 272K = 10K

*Degrees Kelvin or K is the primary unit of temperature measurement in the physical sciences, and is often used in conjunction with degrees Celsius and whenever reference is made to superheat in a refrigeration system. Both K and °C have the same magnitude.

b) Discharge line validation

Analysis of the discharge line is important to establish if high side pressure and temperature is within specifications for correct compressor operation. The pressure level should be within range as recommended by the system manufacturer or the ambient conditions as outlined in the table shown in Condenser performance check below. The discharge line superheat temperature should be within the range of 5-40K. If superheat levels exceed this range, corrective action is required. Further technical advice and assistance is available by referring to *Unicla Booklet B0901 – Unicla General Service Information*

Procedure to calculate discharge superheat:

- 1 Measure pressure** at compressor discharge line outlet.
Example: Gauge pressure = 15.2 bar (220.45 psi)
- 2 Measure temperature** at compressor discharge line outlet. Use an accurate thermocouple clamped securely to the pipe and insulated with cork or foil tape.
Example: 78.0°C (172.4°F)
- 3 Complete superheat calculation** by converting the suction line pressure from Step 1 into temperature (refer to *Pressure/Temperature saturation table – R134a*) and deducting it from the temperature measured on the suction line in Step 2.

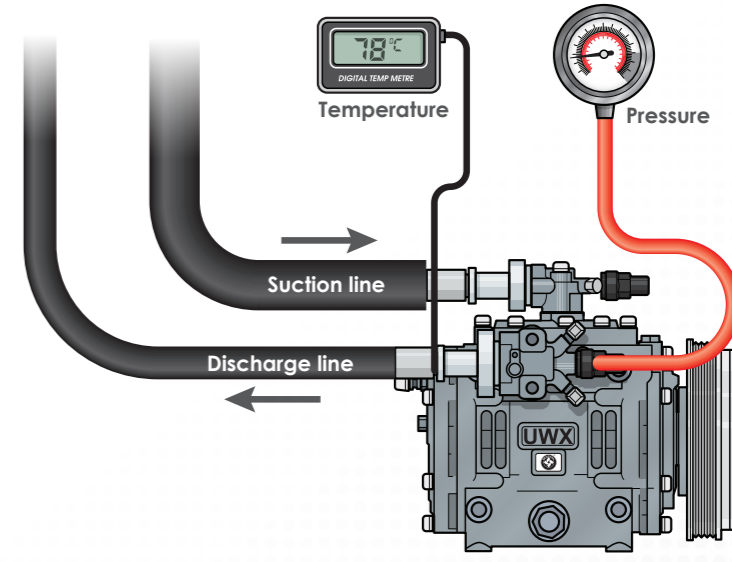

Example:

Step 1: 15.2 bar (220.45 psi) = 58°C
 Step 2: = 78.0°C (172.4°F)
 Step 3: = (78.0°C) – (58.0°C) = 20K

To calculate super heat from Fahrenheit convert to Kelvin scale as follows:

Step 1: 15.2 bar (220.45 psi) = 136.4°F = 331.15K
 Step 2: = 78°C = 172.4°F = 351.15K
 Step 3: = 351.15K – 331.15K = 20K

c) Condenser performance check

The following chart should be used as a guide for UWX compressors to analyse normally acceptable high side (discharge) pressures and discharge line temperatures for given ambient conditions. If temperatures and pressures are outside the recommended range as shown, corrective action is required. Further technical advice and assistance is available by referring to *Unicla Booklet B0901 – Unicla General Service Information*

°C	°F	kPa	PSI	1800 rpm	2200 rpm	3500 rpm	Discharge line superheat range
15	60	600 - 800	90 - 115	37 - 42	42 - 47	50 - 56	7 - 26
18	65	750 - 950	110 - 135	43 - 52	47 - 58	56 - 70	9 - 34
21	70	900 - 1100	130 - 160	50 - 57	55 - 64	66 - 76	10 - 36
24	75	1050 - 1300	155 - 190	58 - 64	66 - 73	77 - 83	12 - 37
27	80	1200 - 1550	185 - 220	65 - 72	73 - 80	75 - 89	13 - 37
30	85	1400 - 1750	200 - 250	68 - 77	75 - 86	79 - 92	14 - 38
33	90	1500 - 1900	215 - 275	72 - 85	80 - 94	89 - 97	14 - 39
35	95	1700 - 2100	245 - 300	77 - 90	86 - 98	93 - 102	15 - 40
38	100	1850 - 2250	265 - 325	85 - 92	94 - 102	• NR	17 > 40
41	105	200 - 2400	290 - 350	88 - 97	97 - 108	• NR	18 > 40
44	110	2250 - 2650	325 - 385	92 - 102	• NR	•• NR	18 > 50
47	115	2500 - 2900	370 - 420	102 - 110	• NR	•• NR	20 > 50

15. Pressure switches

Unicla recommends pressure switches are installed on UWX compressors in the configuration shown in the diagram below. The pressure safety levels of the switches should be at least 23 bar (334 psi) on the high side, and 0.7 bar (10 psi) on the low side.

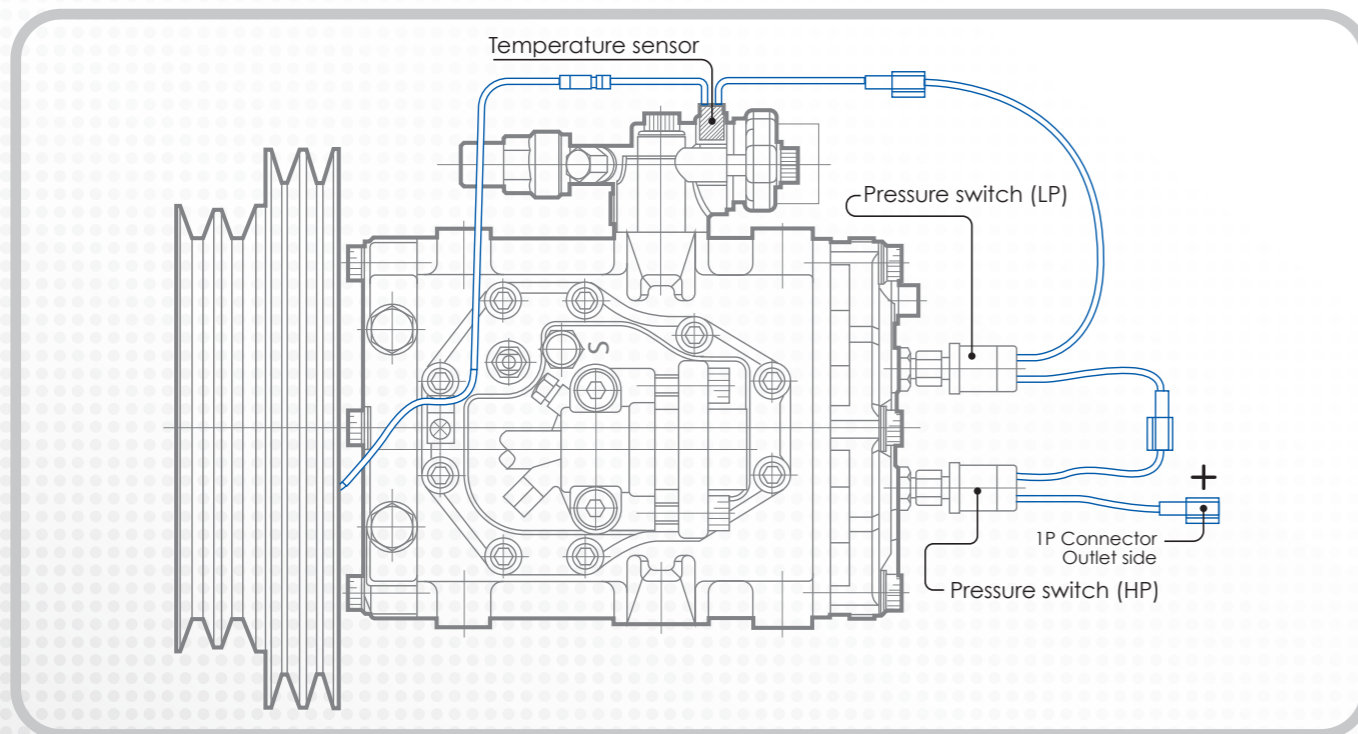

16. Oil separators

An oil separator is recommended for use with UWX series compressors in systems where the oil return to the compressor is potentially lower than it should be, at risk from a design feature in the system, or from adverse conditions created by system operation. These can include:

- Very long hose runs (> 6 metres), particularly in the suction line causing pressure drop and reduced refrigerant and oil flow
- Low evaporator temperatures as found in transport refrigeration systems, causing oil to pool in the evaporator coil

- Large or multiple heat exchangers providing locations for oil to pool, as found in bus and coach rooftop applications
- Air-conditioning systems where the condensing temperature is greater than 50°C and the evaporating temperature is lower than -5°C
- High-revving and continuous compressor operation causing excessive oil discharge from the compressor in relation to oil return.

Oil separators are also recommended in systems where evaporator capacity is marginal and oil in the evaporator is affecting system efficiency. Reducing oil in the evaporator improves evaporator saturation temperatures by allowing optimum heat absorption in the refrigerant.

Unicla oil separators will retain >70% of the original compressor oil level (COL) or approximately 40-60% of the recommended total system oil quantity (SOQ).

Connection options for Unicla oil separator

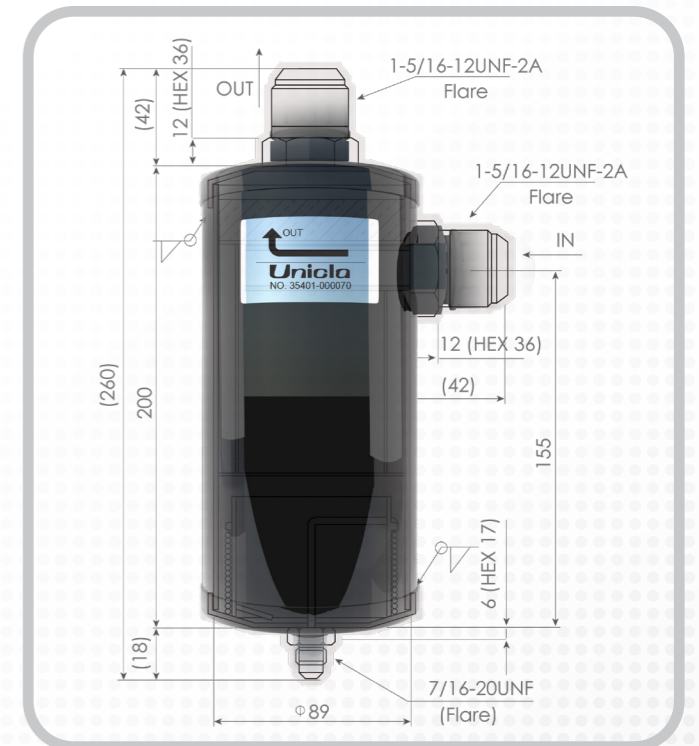
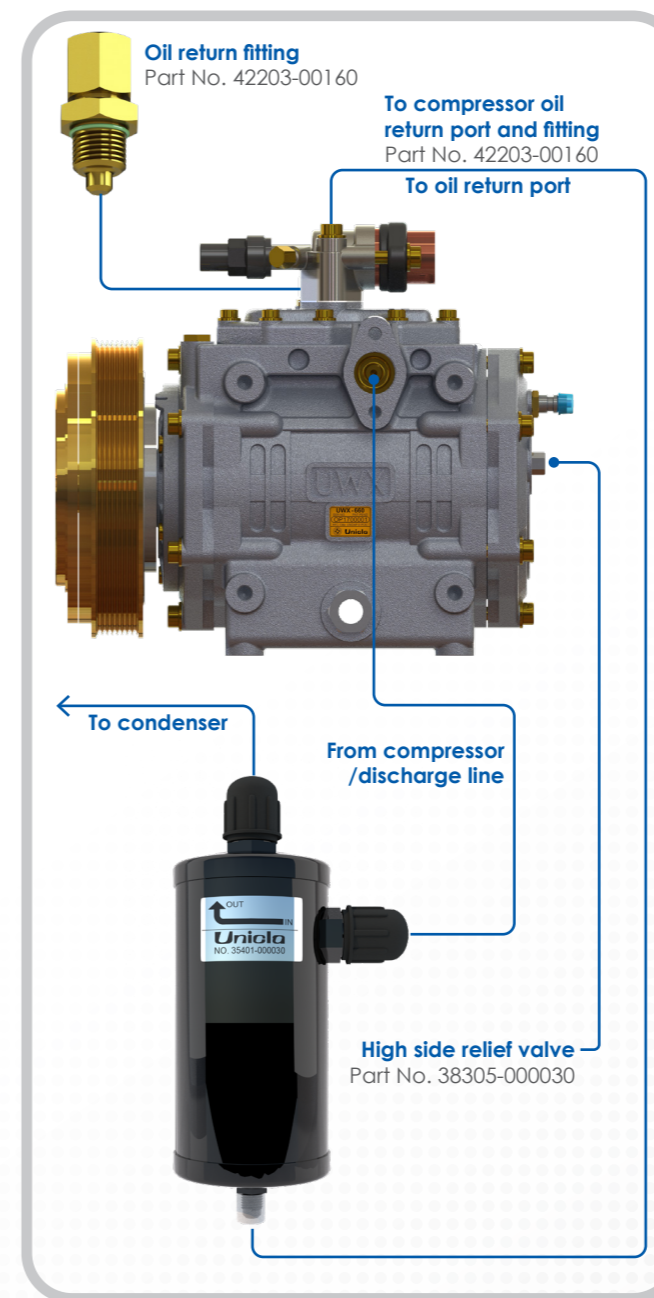

F-Type Oil Separator Part No. 35401-000070

Male flare connections (#16: 1-5/16-12 UNF-2A) for easy integration with the discharge line, and a male flare (7/16-20 UNF) for the oil return line. The F-Type oil separator is ideal for use with all Unicla UWX series compressors (508 to 675 cc).

17. Compressor operation analysis report

To determine the performance of a Unicla UWX compressor in a specific application, the following Compressor Operation Analysis Report will assist in the collection of the necessary data.

Vehicle Details			
Date		Ref	
Owner Name			
Contact Details			
Phone			
AC System Type			
Compressor Details			
Compressor Model		Date Purchased	
Clutch Type		Invoice Number	
Clutch Voltage		Date Installed	
		Vehicle Type	
System Information			
Refrigerant	R134a / Other	UV Dye Added	Yes / No
Purity	%	Oil Separator Fitted	Yes / No
Oil Type		Accumulator Fitted	Yes / No
Discharge	Suction	Other	
Operation Analysis at 1200 / 1500 / 1800 RPM (Indicate which)			
Discharge Pressure	Suct. Pressure at Evap	Duct Temp - In	°C
Condenser Temp	Suct. Pressure at Comp	Duct Temp - Out	°C
Discharge Temp	Pressure Drop	Temp Difference	°C
Liquid Line Temp	Suct. Line Temp at Comp	Airflows	
Discharge Superheat	Evap Temp	Condenser	m/s
Subcooling	Suct. Line Temp at Evap	Evap Duct - Front	m/s
	Suct. Line Superheat	Evap Duct - Rear	m/s
Operation Analysis at 2000 / 2200 / 2400 RPM (Indicate which)			
Discharge Pressure	Suct. Pressure at Evap	Duct Temp - In	°C
Condenser Temp	Suct. Pressure at Comp	Duct Temp - Out	°C
Discharge Temp	Pressure Drop	Temp Difference	°C
Liquid Line Temp	Suct. Line Temp at Comp	Airflows	
Discharge Superheat	Evap Temp	Condenser	m/s
Subcooling	Suct. Line Temp at Evap	Evap Duct - Front	m/s
	Suct. Line Superheat	Evap Duct - Rear	m/s
Operation Analysis at 2500 / 3000 / 3600 RPM (Indicate which)			
Discharge Pressure	Suct. Pressure at Evap	Duct Temp - In	°C
Condenser Temp	Suct. Pressure at Comp	Duct Temp - Out	°C
Discharge Temp	Pressure Drop	Temp Difference	°C
Liquid Line Temp	Suct. Line Temp at Comp	Airflows	
Discharge Superheat	Evap Temp	Condenser	m/s
Subcooling	Suct. Line Temp at Evap	Evap Duct - Front	m/s
	Suct. Line Superheat	Evap Duct - Rear	m/s
Other Information			
Ambient Temp	°C	Clutch Cycle (set point)	°C
Comp oil Level			cc
Note: Measure compressor oil level by sight glass for models 330, 440 & 550.			

18. Installation and commissioning checklist

This check list follows the important steps required to ensure the Unicla UWX compressor is installed and operating within Unicla recommended guidelines. This list should be completed after every installation from the form supplied with the compressor. If further information or corrective action is required at any point, further technical advice and assistance is available by referring to Unicla Booklet B0901 - Unicla General Service Information, Unicla Booklet B1801 - The Importance of Suction Lines: Analysis and Connection to Compressors, Unicla booklet B1802 - Oil and compressor lubrication.

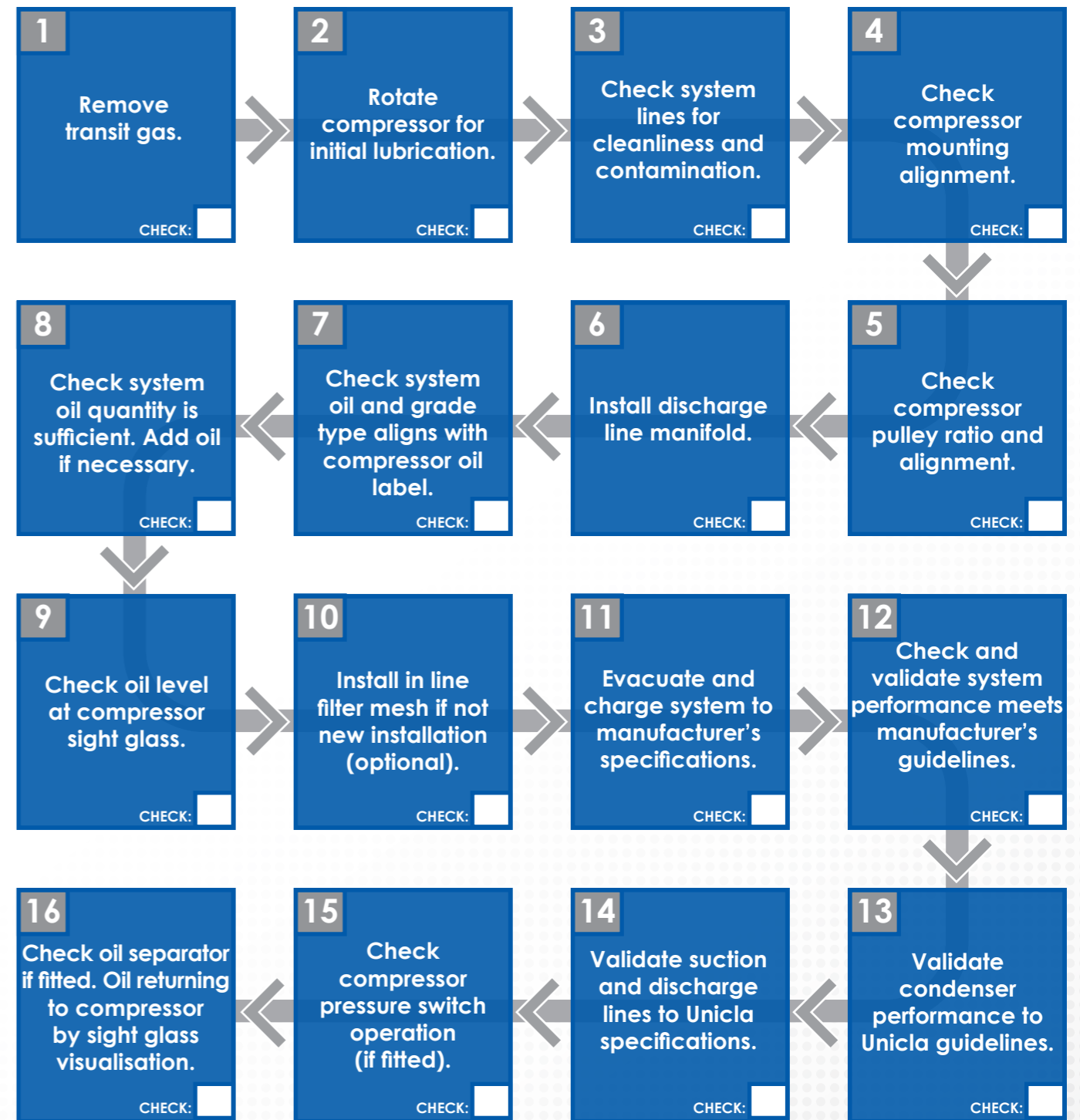

Checked by: _____

Date: _____

Signed: _____

Company: _____



HEAD OFFICE

Unicla International Limited

Unit 1109, 11/F, Manhattan Centre, 8 Kwai Cheong Road,
Kwai Chung, N.T., Hong Kong

PHONE: +852 2422 0180

FAX: +852 2422 0680

EMAIL: sales@unicla.hk

www.unicla.hk

Unicla Australia

14 Motorway Circuit Ormeau,
Queensland 4208 Australia

PHONE: +61 7 5549 4033

FAX: +61 7 5549 4044

EMAIL: sales@unicla.hk

www.unicla.hk